

ILFOLAB 2150RC SIMPLIFIED INSTRUCTIONS

OPERATING

PROCESSING

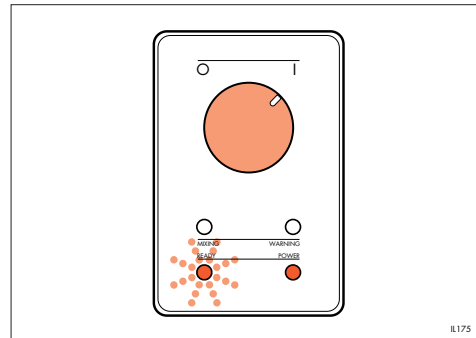

1 Ensure processor lid is closed, water and electrical supplies are on. Turn processor control switch to 'I'. The 'ready' light flashes - processor is not ready for use.

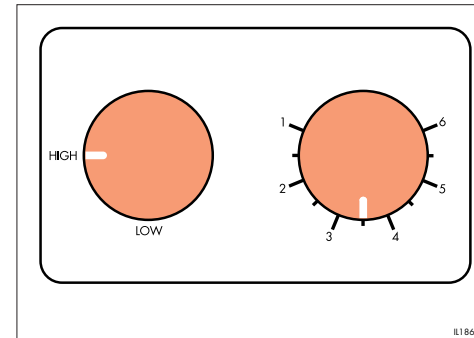

2 Adjust dryer temperature to establish the optimum setting. Select High for gloss papers, select low for matt or pearl papers. Start at position 3.5 and work from there.

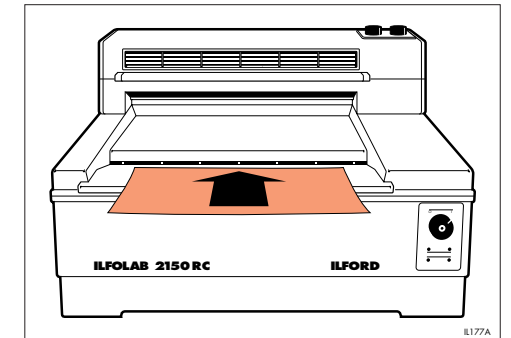

3 When 'ready' light is steady on, feed sheets emulsion side down with long edge leading. Wait for the audible signal before feeding in the next sheet.

SWITCHING OFF

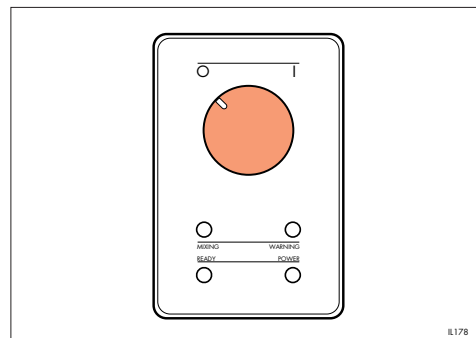

1 At the end of the working period, turn the processor control switch to 'O'.

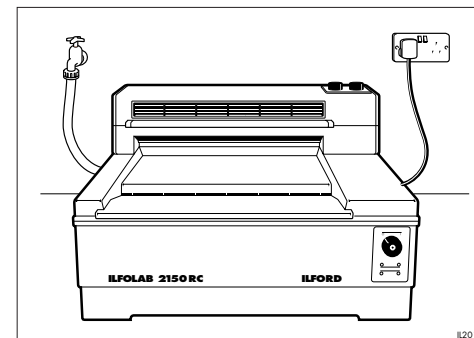

2 Turn off the water and electrical supplies.

DRAINING AND RINSING

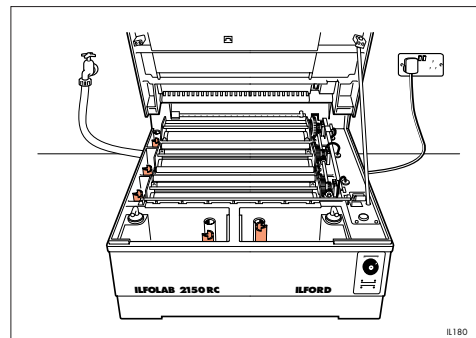

1 Draining
Drain the developer, fixer and wash water by releasing the five standpipes. Drain one tank at a time, and drain the fixer before the developer. Re-tighten the standpipes.

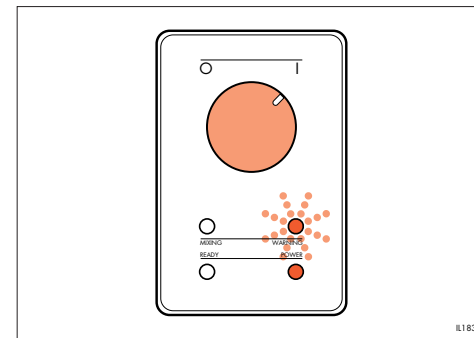

2 Switch the processor on.
Note
The 'warning' light remains on during the initial systems check.

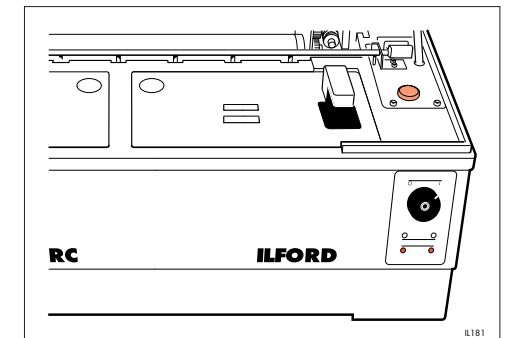

3 Automatic rinsing
Raise processor lid, press water feed button and hold for 3 seconds until water flows. Lower lid. The processor runs for 2 minutes and then gives 3 audible signals and stops. Switch the processor off. Drain the processor.