

**ILFORD**

50/60Hz

**SERVICE INFORMATION**

# **ILFOLAB 1250 RC**

VARIABLE SPEED PRINT DRYER FOR HIGH QUALITY  
BLACK AND WHITE PRINT DRYING.

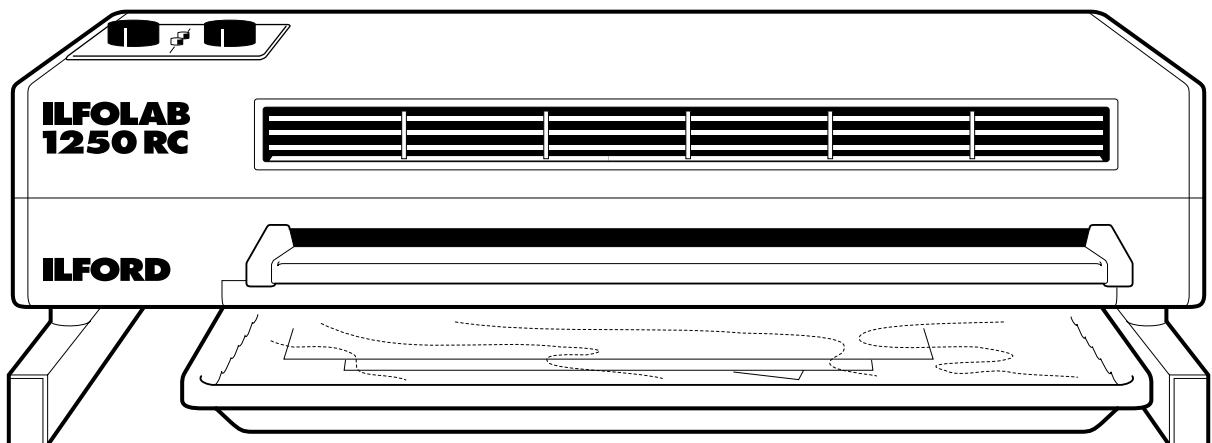

IL882



---

---

---

# CONTENTS

	<b>APPROVED ABBREVIATIONS</b>	3
<b>1</b>	<b>PARTS LIST</b>	4
<b>2</b>	<b>ELECTRICAL</b>	15

---

# APPROVED ABBREVIATIONS

The following is a list of abbreviations used on the parts list and circuit diagrams:

<b>Abbreviation</b>	<b>Word(s) in full</b>
AR	as required
assy	assembly
CT	control, temperature
csk hd	countersunk head
dev	developer
d	diameter
fig	figure
fix	fixer
flex hose	flexible hose
hex head	hexagonal head
id	inside diameter
lh	left hand
LED	light emitting diode
no.	number
od	outside diameter
overflow	overflow
phd	pan head
PCB	printed circuit board
RL	relay
rep	replenishment
rh	right hand
stap	self tapping
sproof	shakeproof
ss	stainless steel
SW	switch
T	teeth
temp	temperature
TB	terminal block

# 1

---

## PARTS LIST

When ordering spare parts, please quote the correct part number in order that ILFORD Imaging UK Limited can process your order as quickly and efficiently as possible.

<b>Figure</b>	<b>Description</b>	
1.1	ILFOLAB 1250RC dryer - body upper	5
1.2	ILFOLAB 1250RC dryer - body lower	9
1.3	ILFOLAB 1250RC dryer - moving parts	11
1.4	ILFOLAB 1250RC dryer - moving parts	13

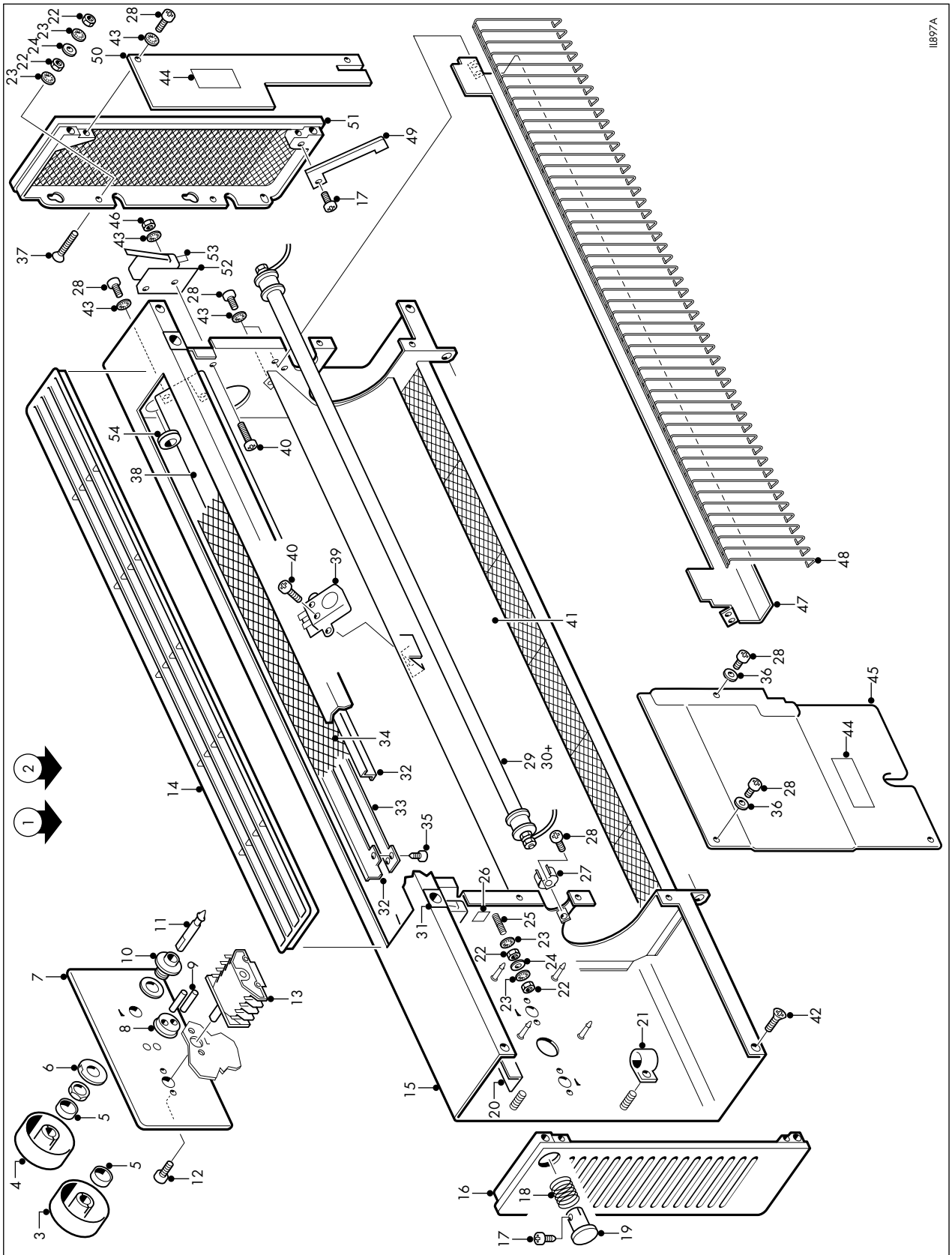

**Figure 1.1**

ILFOLAB 1250RC dryer - body upper

## 1.1 ILFOLAB 1250RC dryer - body upper

Ref no. fig 1.1	Part no.	Description	Quantity	Serial no.
1	6216-0-001	ILFOLAB 1250RC dryer, 230V	1	from 1C10001
2	6218-0-001	ILFOLAB 1250RC dryer, 120V	1	from 1A10402
3	6123-4-497	Knob	1	
4	6123-4-470	Control knob	1	
5	81339515	Compression ring	2	
6	6123-4-471	Tag washer	1	
7	6123-3-473	Control panel	1	
8	6216-4-102	Light pipe housing	1	
9	6216-4-103	Light pipe	2	
10	6216-4-100	Support bush	1	
11	6216-4-110	Pot adjustment shaft	1	
12	87992635	Screw, M4x8mm, phd	1	
13	87998623	Switch, rotary (SW1)	1	
14	6123-2-191	Air grille	2	
15	6123-P-003	Top cover sub assy	1	
16	6123-P-432	End cap upper lh sub assy	1	
17	87992637	Screw, M4x12mm, phd	2	
18	6123-4-121	Release button return spring	1	
19	6122-3-139	Release button	1	
20	6123-2-140	Locking bar	1	
21	81334756	P clip	1	
22	86203942	Nut, M4, brass	4	
23	89730601	Washer, M4, sproof	4	
24	89730445	Washer, M4, plain	6	
25	87989660	Screw, M4x20mm, phd	1	
26	6123-4-161	Earth label	1	
27	81334752	Clip, heater connector	2	
28	87992607	Screw, M3x6mm, phd	16	
29	6126-3-116	Heater, 450W 230V (H1)	1	
30+	6218-3-116	Heater, 450W 120V (H1)	1	
31	6123-4-186	Locking pin bush	2	
32	6123-3-481	Air grille fixing plate	4	
33	6123-3-482	Air grille cable plate	1	
34	6123-3-184	Air grille mesh	2	
35	87991746	Screw, M3x6mm, stap phd	12	
36	89730466	Washer, M3, plain	3	
37	87990339	Screw, M4x16mm, csk hd	2	
38	6123-3-475	Upper deflector	1	
39	89014413	Thermal cutout	1	
40	87992612	Screw, M3x20mm, phd	4	
41	6123-2-468	Fan air deflector	1	
42	87993024	Screw, M4x6mm, csk hd	4	
43	89730600	Washer, M3, sproof	21	
44	6200-3-108	Label, electrical hazard	2	
45	6123-2-221	Upper cover, lh	1	
46	86204065	Nut, M3	2	
47	6123-2-469	Upper reflector	1	
48	6123-2-132	Upper reflector guide	1	
49	6123-3-145	Restraining arm	1	
50	6123-3-146	Upper cover, rh	1	

---

### 1.1 ILFOLAB 1250RC dryer - body upper

Ref no. fig 1.1	Part no.	Description	Quantity	Serial no.
51	6123-P-021	End cap, upper roller sub assy	1	
52	6123-4-143	Switch insulator plate	2	
53	6123-4-193	Microswitch (SW2,SW3)	2	
54	81334727	Open/close bush No. 2872, black	2	

+ items not illustrated





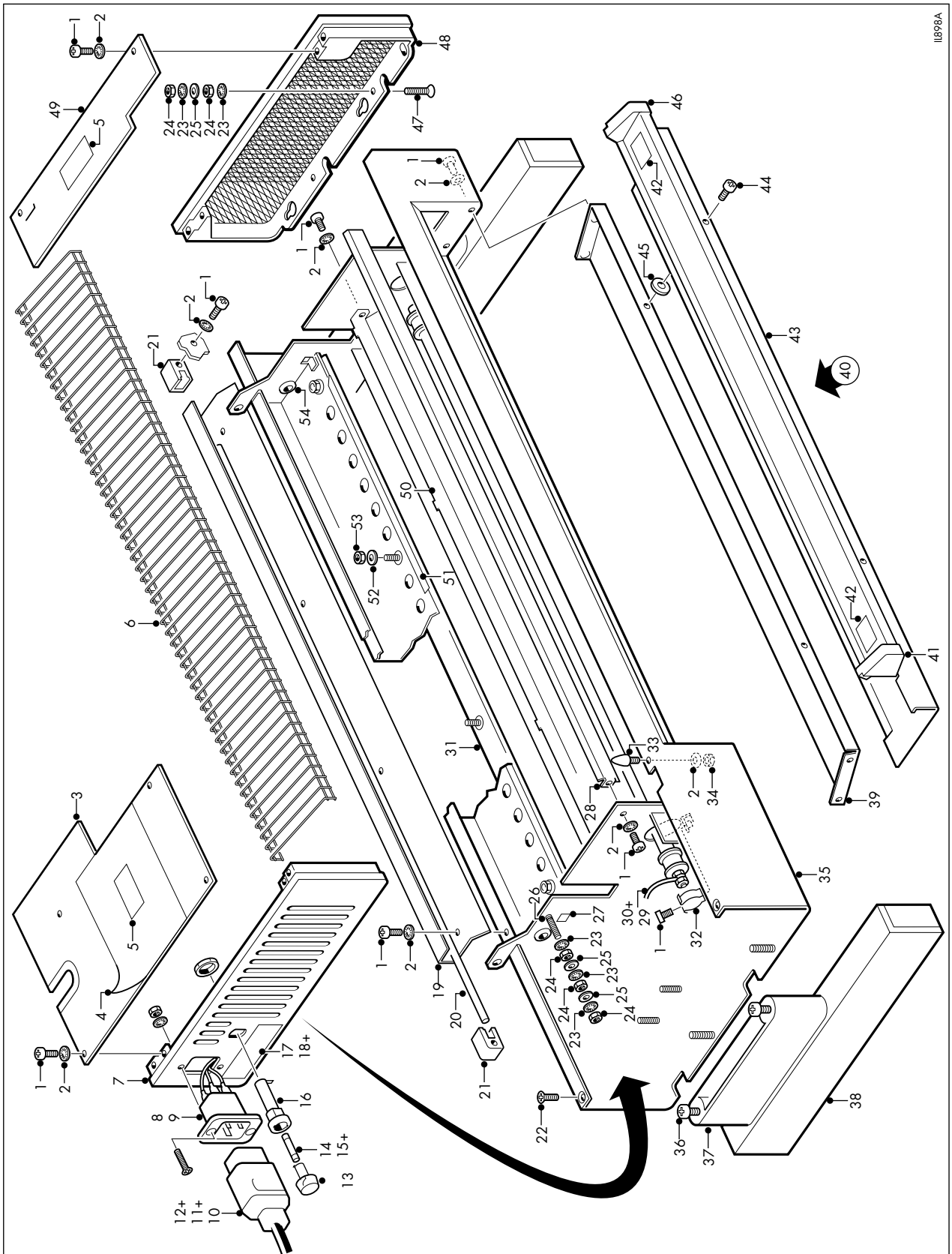

ILB98A

**Figure 1.2**

ILFOLAB 1250RC dryer - body lower

## 1.2 ILFOLAB 1250RC dryer - body lower

Ref no. fig 1.2	Part no.	Description	Quantity	Serial no.
1	87992607	Screw, M3x6mm, phd	21	
2	89730600	Washer, M3, sproof	20	
3	6123-2-222	Lower cover, lh	1	
4	6123-4-162	Caution label	1	
5	6200-3-108	Label, electrical hazard	2	
6	6123-2-134	Lower reflector guide	1	
7	6123-P-022	End cap, lower lh sub assy	1	
8	86618566	Power connector, IEC320	1	
9	86618567	Connector lock	1	
10	81335140	Mains lead, UK	1	
11+	81335141	Mains lead, Europe	1	
12+	81335142	Mains lead, US	1	
13	83421260	Bayonet cap	1	
14	83421249	Fuse, 6A fast blow (F1)	1	
15+	83421250	Fuse, 12A fast blow (F1)	1	
16	83421259	Fuseholder	1	
17	6123-4-459	Rating label, 230V	1	
18+	6123-4-467	Rating label, 120V	1	
19	6123-3-112	Hinge pin cover	1	
20	6123-4-109	Hinge pin	1	
21	6122-3-113	Hinge pin cap	2	
22	87993024	Screw, M4x6mm, csk hd	2	
23	89730601	Washer, M4, sproof	10	
24	86203942	Nut, M4, brass	10	
25	89730445	Washer, M4, plain	12	
26	87989660	Screw, M4x20mm, phd	1	
27	6123-4-161	Earth label	2	
28	6123-3-128	Heat deflector	1	
29	6216-3-116	Heater, 450W 230V (H2)	2	
30+	6218-3-116	Heater, 450W 120V (H2)	1	
31	6123-3-472	Nip exit guide	1	
32	81334752	Clip, heater connector	2	
33	6122-4-138	Locking pin	2	
34	86204065	Nut, M3	2	
35	6123-P-439	Base cover assy	1	
36	87990151	Screw, M6x60mm, phd	4	
37	6122-2-152	Foot spacer	2	
38	6123-P-058	Foot bung assy	2	
39	6123-1-119	Drip tray	1	
40	6123-P-059	Feed tray/end cover assy	1	
41	6122-3-137	End cap, feed tray, lh	1	
42	6216-4-111	Finger nip label	2	
43	6123-1-120	Feed tray	1	
44	6123-4-122	Locating screw, feed tray	2	
45	6123-4-131	Retaining washer, fibre	2	
46	6122-2-136	End cap, feed tray, rh	1	
47	87990339	Screw, M4x16mm, csk hd	3	
48	6123-P-023	End cap, lower rh sub assy	1	
49	6123-3-148	Lower cover, rh	1	
50	6123-P-053	Lower reflector assy	1	
51	6123-2-177	Liner plate	1	
52	6123-4-213	Washer, nip exit guide	4	
53	86204066	Nut, M4	4	
54	83883507	Grommet	2	

+ items not illustrated

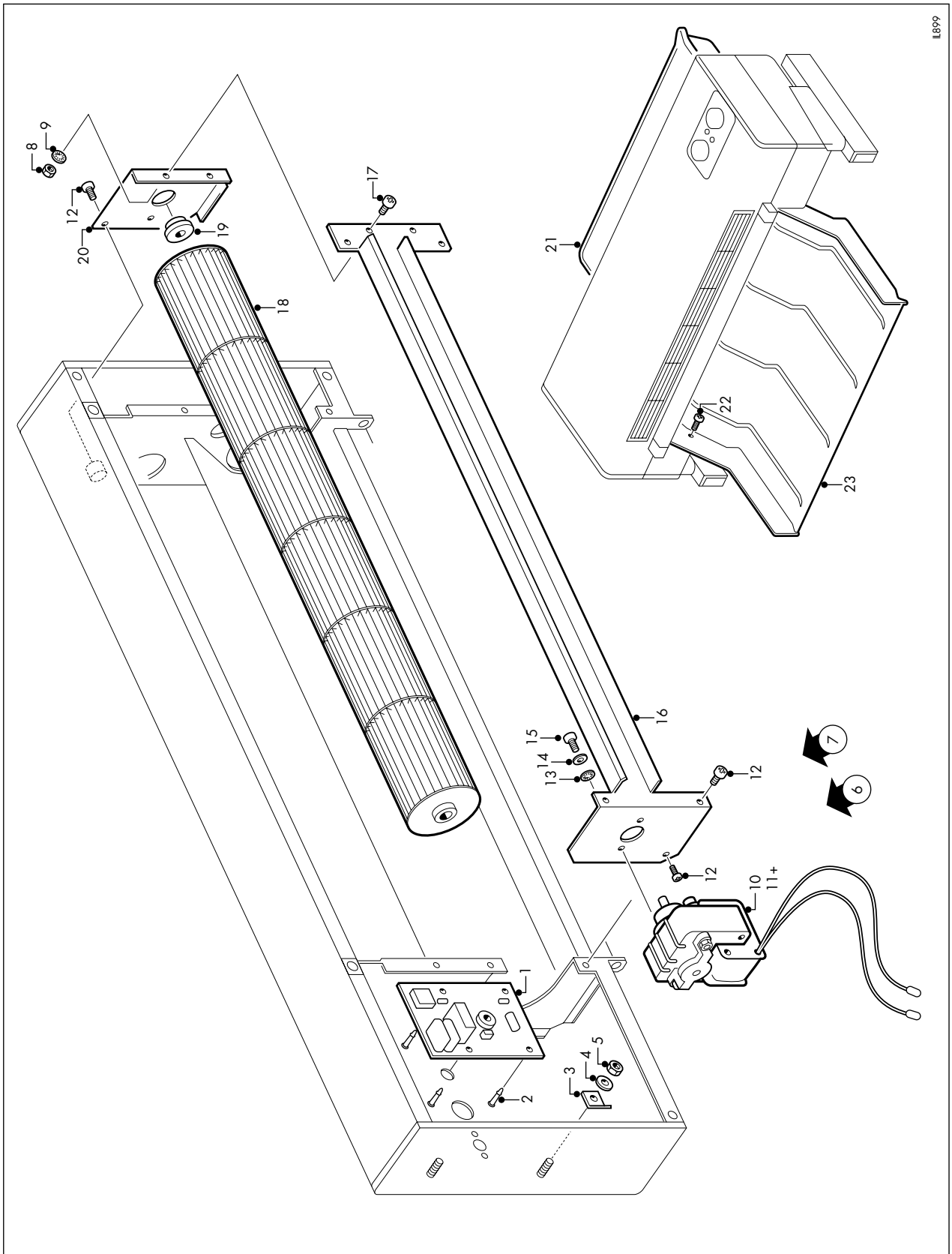

**Figure 1.3**

ILFOLAB 1250RC dryer - moving parts

### 1.3 ILFOLAB 1250RC dryer - moving parts

Ref no. fig 1.3	Part no.	Description	Quantity	Serial no.
1	6216-3-105	Controller - ACL (PCB1)	1	
2	82956921	PCB support post	4	
3	6122-4-161	Earth connector spring plate	4	
4	89730707	Washer, M6, plain	4	
5	86204068	Nut, M6	4	
6	6216-P-009	Fan assy, 230V 50Hz	1	
7	6218-P-009	Fan assy, 120V 60Hz	1	
8	86204065	Nut, M3	2	
9	89730600	Washer, M3, sproof	4	
10*	6123-3-048	Fan motor and cable assy, 230V (M1)	1	
11*	6123-3-049	Fan motor and cable assy, 120V (M1)	1	
12	87992607	Screw, M3x6mm, phd	7	
13*	89730717	Washer, M3.5, sproof	2	
14*	89730705	Washer, M3.5, plain	2	
15*	87991753	Screw, M3.5x8mm, phd, stap	2	
16*	6123-2-117	Mounting bracket, fan	2	
17	87992608	Screw, M3x8mm, phd	2	
18*	6123-4-218	Fan rotor	1	
19*	83419209	Bearing, fan	1	
20*	6123-3-118	Fan mounting bracket, rh	1	
21	6004-1-186	Dish	1	
22	87992635	Screw, M4x8mm, phd	1	
23	6123-2-138	Print receive tray	1	

+ items not illustrated

\* These items are not available as spare parts. Items 6 and 7 are supplied as complete assemblies to ensure correct fan balancing.

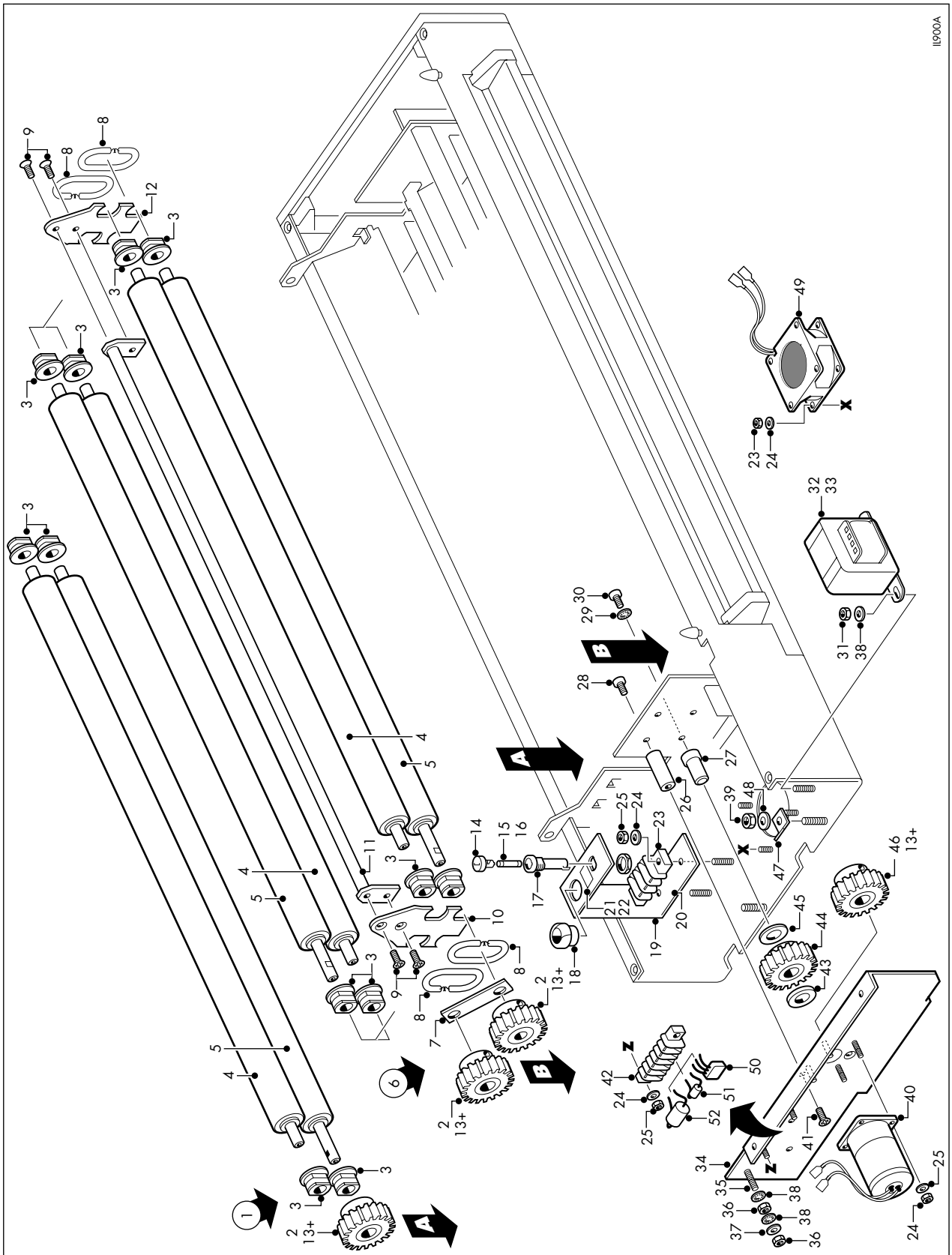

ILF00A

**Figure 1.4**

ILFOLAB 1250RC dryer - moving parts

## 1.4 ILFOLAB 1250RC dryer - moving parts

Ref no. fig 1.4	Part no.	Description	Quantity	Serial no.
1	6123-P-056	Output drive roller assy	1	
2	6123-P-178	Gear, 40T	3	
3	6123-4-179	Bearing, roller	3	
4	6123-P-008	Driven roller assy	1	
5	6123-P-007	Roller, drive	3	
6	6123-P-057	Front roller unit assy	1	
7	6123-4-182	Locating plate	1	
8	6123-3-114	Roller tension spring	4	
9	87992997	Screw, M3x6mm, csk hd	4	
10	6123-3-180	Side plate, lh	1	
11	6123-P-055	Torque rod assy	1	
12	6123-3-181	Side plate, rh	1	
13+	87993146	Socket set screw, M4x10mm	4	
14	83421261	Bayonet cap	1	
15	83421234	Fuse, 125mA 250V (F2)	1	
16	83421235	Fuse, 250mA 250V (F2)	1	
17	83421259	Fuseholder	1	
18	81334755	Strain relief bush	1	
19	6216-3-121	Cable support bracket	1	
20	6216-4-113	Label, neutral	1	
21	6216-4-112	Fuse label 125mA	1	
22	6218-4-115	Fuse label 250mA	1	
23	89013020	Terminal block 3-way (TB1)	1	
24	89730466	Washer, M3, plain	8	
25	86204065	Nut, M3	8	
26	6122-4-118	Motor spacer	2	
27	6122-3-119	Idler gear spigot	1	
28	87992634	Screw, M4x6mm, phd	2	
29	89730600	Washer, M3, sproof	1	
30	87992607	Screw, M3x6mm, phd	1	
31	86204066	Nut, M4	2	
32	89014211	Transformer, 230V (T1)	1	
33	89014207	Transformer, 120V (T1)	1	
34	6123-2-629	Motor mounting plate	1	
35	87989659	Screw, M4x16mm, phd	1	
36	86203942	Nut, M4, brass	4	
37	89730445	Washer, M4, plain	3	
38	89730601	Washer, M4, sproof	8	
39	86204068	Nut, M6	4	
40	85657530	Drive motor, 12Vdc (M2), Maxon	1	
41	87993024	Screw, M4x16mm, csk hd	2	
42	89013038	Terminal block 6-way	1	
43	89730710	Washer, nylon	1	
44	6122-3-114	Gear, 40T idler	1	
45	89730711	Washer, nylon	1	
46	6122-P-014	Gear, motor	1	
47	6122-4-161	Earth connector spring plate	2	
48	89730707	Washer, M6, plain	4	
49	83419223	Fan, 24V dc, (M3)	1	
50	87560803	Diode bridge, (D1)	1	
51	81334961	Capacitor, fan, (C1)	1	
52	81334962	Capacitor, motor, (C2)	1	

+ items not illustrated

# 2

---

## ELECTRICAL

<b>Figure</b>	<b>Description</b>	
2.1	ILFOLAB 1250RC dryer circuit and component layout	16
2.2	PCB1 component layout	17
2.3	PCB1 circuit diagram	18



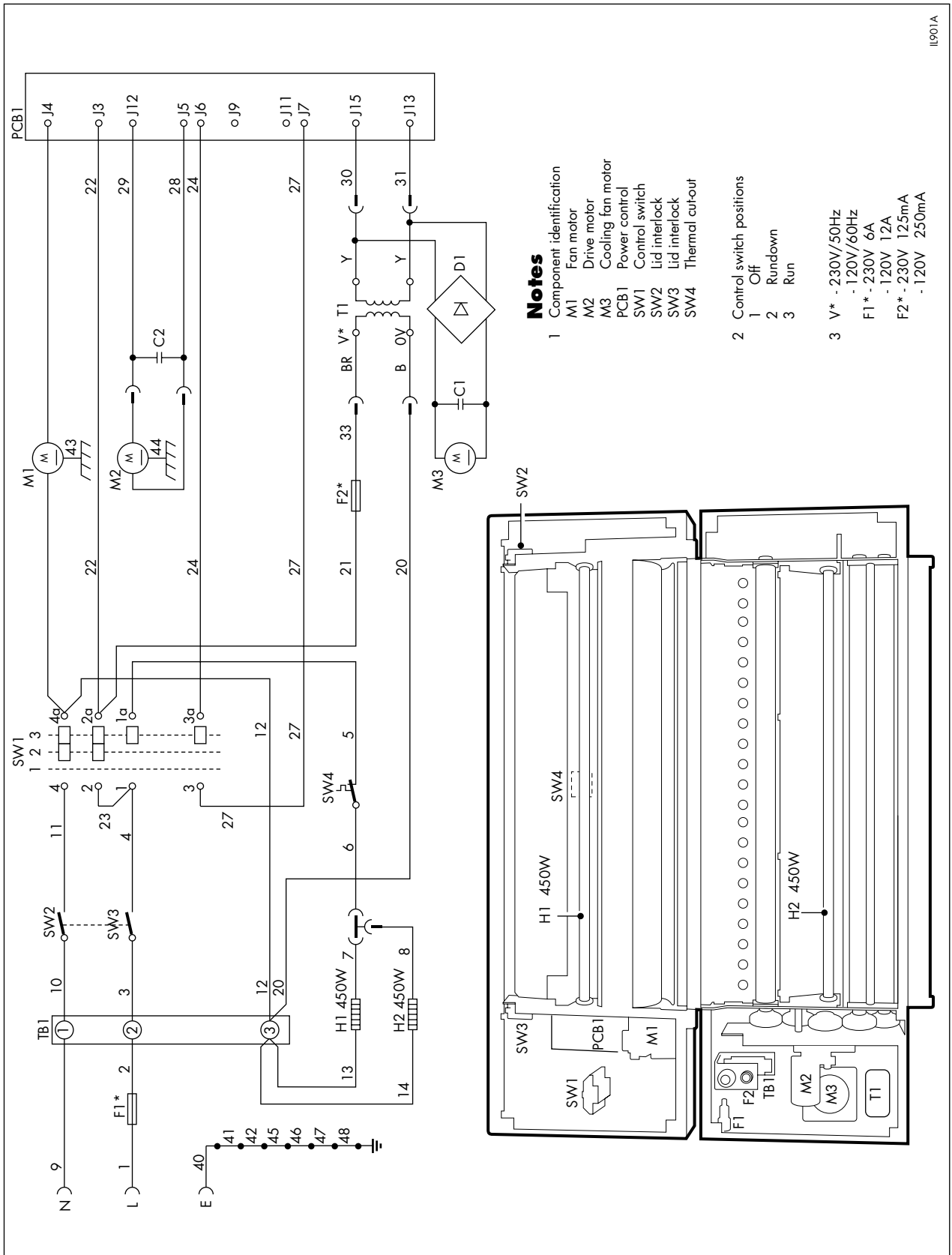

IL901A

**Figure 2.1**

ILFOLAB 1250RC dryer circuit and component layout

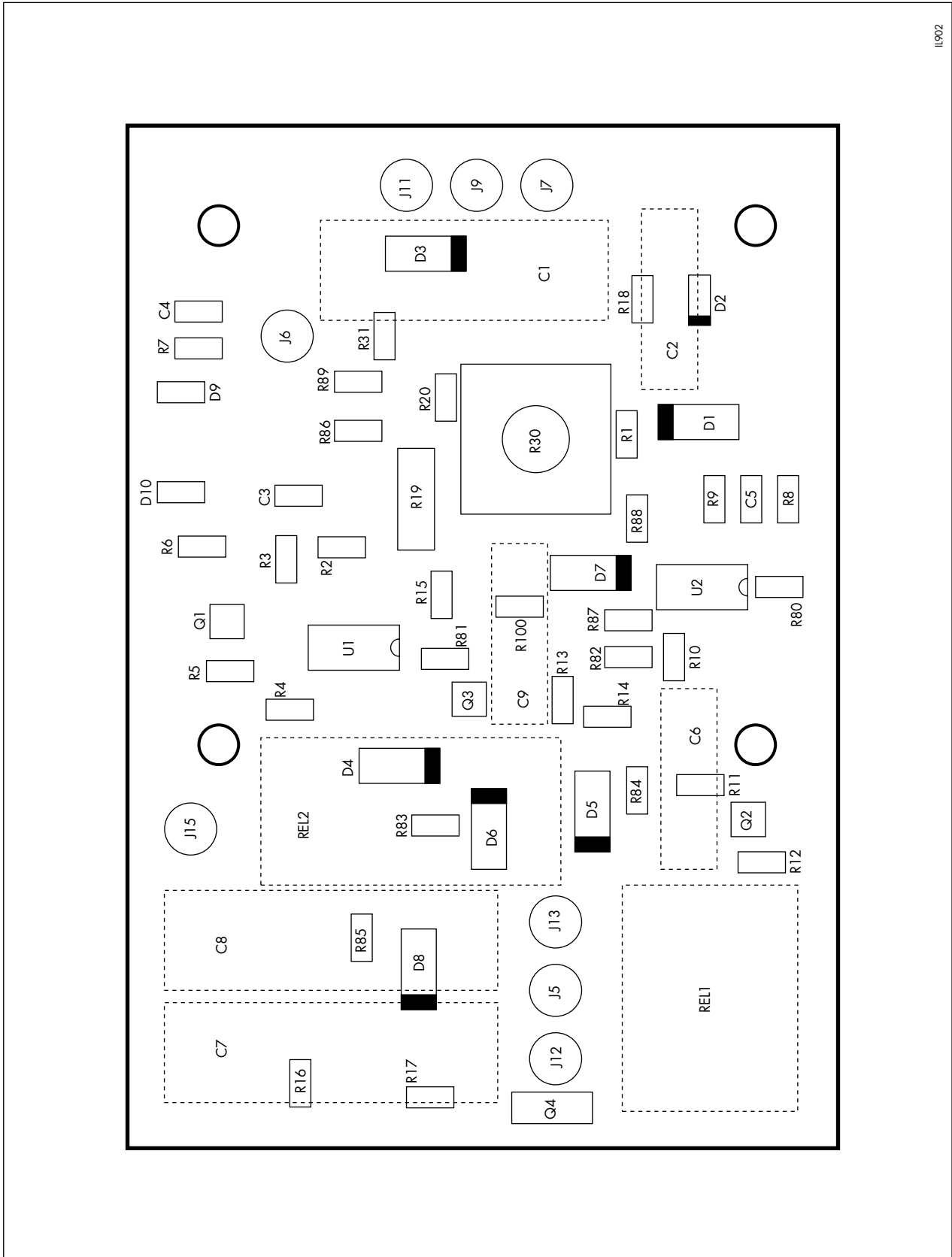

**Figure 2.2**

PCB1 component layout

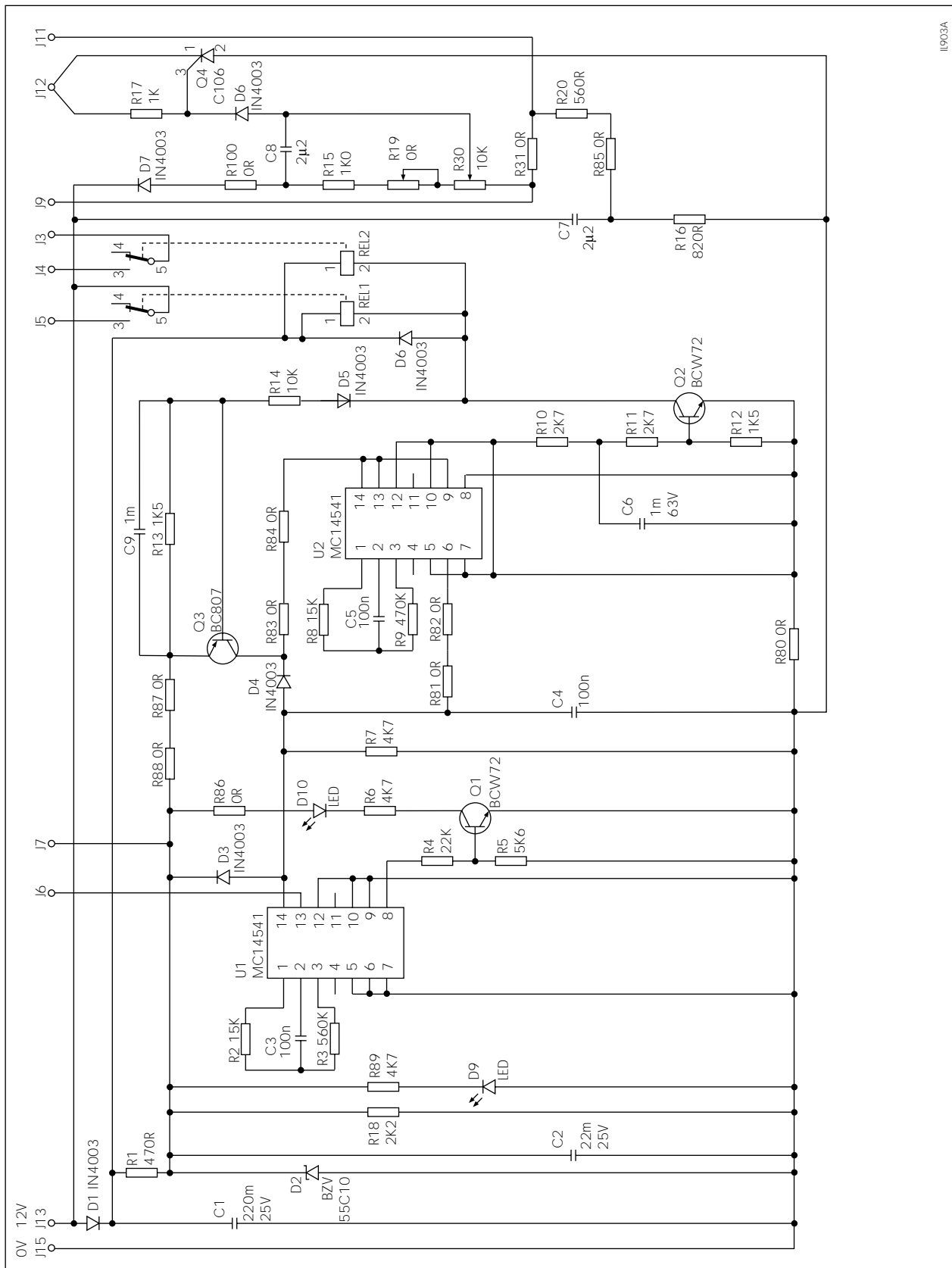

II903A

**Figure 2.3**

PCB1 circuit diagram

**Australia**

ILFORD Imaging Australia Pty Limited  
Cnr. Ferntree Gully & Forster Roads  
PO Box 144  
Mt Waverley  
Victoria 3149

**Benelux**

ILFORD Imaging Nederland BV  
Nieuwenhuizenweg 10  
Postbus 1125  
NL-2302 BC Leiden  
Holland

**Canada**

ILFORD Imaging Canada Limited  
361 Steelcase Road West  
Unit No.4  
Markham  
Ontario L3R 3V8

**France**

ILFORD Imaging France SA  
10 Allée Des Ginkgos  
F-69673 Bron - Cedex

**Germany/Austria**

ILFORD Imaging GmbH  
Heinrich-Hertz-Str 1  
POB 10 11 68  
D-63265 Dreieich

**Italy**

ILFORD Imaging Italia SpA  
Corso Italia 13  
21047 Saronno (VA)

**Switzerland**

ILFORD Imaging Switzerland GmbH  
Route de l'Ancienne Papeterie  
Case postale 160  
1723 Marly 1

**United Kingdom**

ILFORD Imaging UK Limited  
Town Lane  
Mobberley  
Cheshire WA16 7JL

**USA**

ILFORD Imaging USA Inc  
West 70 Century Road  
Paramus  
New Jersey 07653

If your country is not shown here,  
please contact:

Export Eastern Hemisphere  
ILFORD Imaging UK Limited  
Mobberley  
Cheshire WA16 7JL  
England

Web  
[www.ilford.com](http://www.ilford.com)

Constant improvements in ILFORD products mean that changes in design or specification may occur from time to time. Any improvements will, however, maintain conformance of the product with all relevant legislation. The right to alter the design and specification of the equipment without prior notice is accordingly reserved.

Product names printed in capitals are ILFORD trade marks.  
ILFORD Imaging UK Limited  
Mobberley Cheshire England