

50/60Hz

ILFORD
OPERATING MANUAL

ILFORD
MULTIGRADE
600

VARIABLE CONTRAST
ENLARGER HEAD AND CONTROL SYSTEM

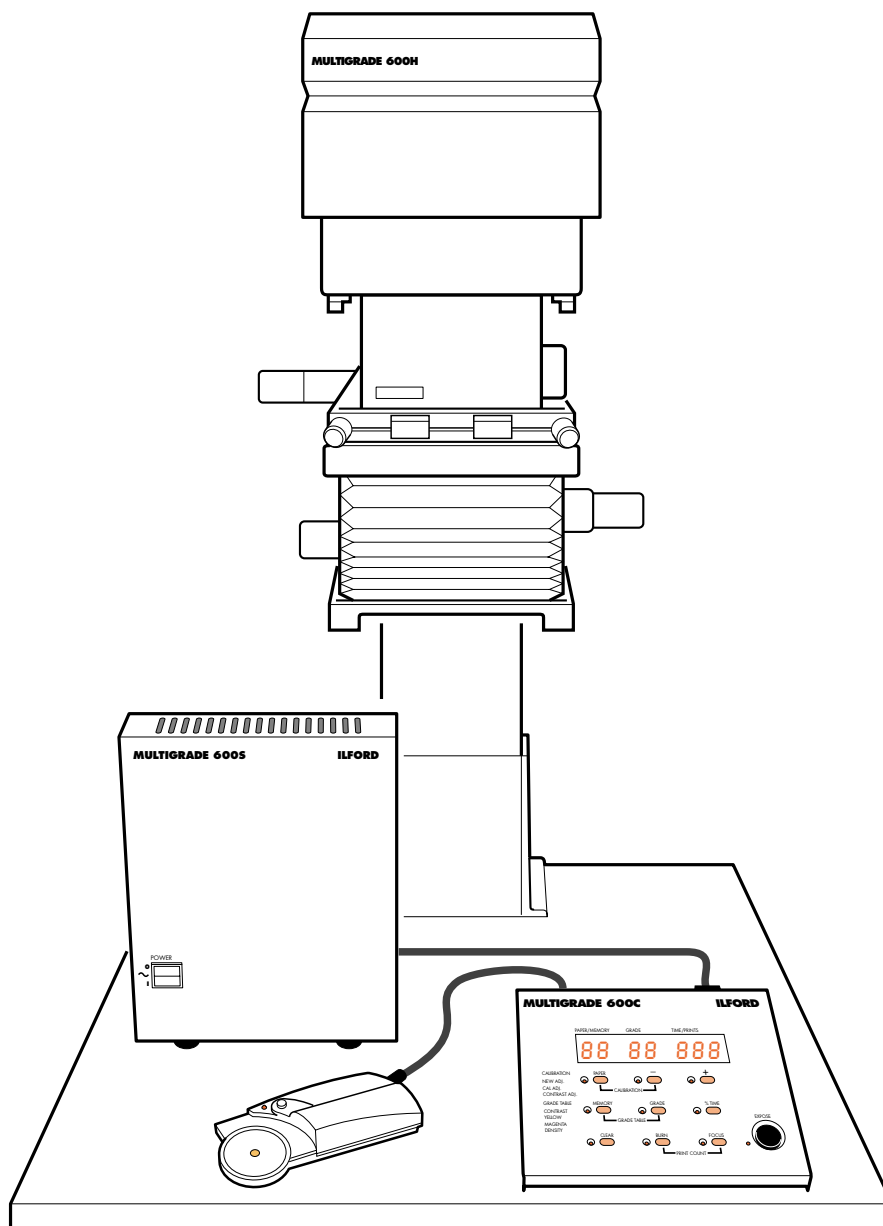

SAFETY PRECAUTIONS

Your photographic equipment is powered by mains electricity, and is designed to comply with international electrical safety standards. However, basic safety precautions must always be followed when operating electrical equipment, including the following, where applicable:

- 1 Read and understand all instructions.
- 2 Observe labels on the equipment, particularly those advising of possible hazards.
- 3 Close supervision is necessary when the equipment is being used by inexperienced personnel.
- 4 Take care to avoid burns. Some internal parts of the equipment can become very hot with continuous use.
- 5 Do not operate equipment that has been dropped or damaged, or has damaged electrical leads. Have the equipment examined by qualified personnel.
- 6 Do not allow any electrical lead to touch hot surfaces.
- 7 To comply with safety and EMC requirements, ensure that the mains socket provides a proper connection to earth.
- 8 Ensure the leads are arranged such that they cannot be pulled or tripped over.
- 9 Ensure the air flow through the vents is not obstructed when operating the equipment. An obstructed air vent can lead to overheating.
- 10 Do not dismantle the equipment unless you are qualified to do so. Incorrect assembly can cause hazards both to yourself and to the equipment.
- 11 Always obey local codes of practice, particularly for installation requirements.

Do not destroy these instructions

CONTENTS

1	INTRODUCTION	5
1.1	Optional extras	5
2	DESCRIPTION	6
2.1	MULTIGRADE 600H enlarger head	6
2.1a	Light source	6
2.1b	Light mixing boxes	7
2.2	MULTIGRADE 600C control unit	7
2.3	MULTIGRADE 600S power supply	8
2.4	MULTIGRADE 600P exposure probe	9
2.5	MULTIGRADE 600F footswitch	9
2.6	Automatic roll easel	10
2.7	Photographic papers	10
2.7a	MULTIGRADE paper	10
2.7b	Other papers	10
3	CONTROLS	11
3.1	Contrast selection	11
3.2	Electronic timer	11
3.3	Expose	12
3.4	Focus	12
3.5	Prints counter	12
3.6	Paper channel selection	13
3.7	Manual burning-in	13
3.8	Burning-in operations using the memory	13
3.9	Calibration	14
3.10	Grade table	14
3.11	Clear button	14
4	INSTALLATION	15
4.1	Enlarger head	15
4.1a	Changing light mixing boxes	15
4.2	Power supply	17
4.2a	Supply voltage	17
4.2b	Working environment	18
4.2c	Connection to mains supply	18
4.3	Enlarger head	18
4.4	Control unit	18
4.5	Footswitch	18
4.6	Exposure probe	18
5	PRINT MAKING STANDARD METHOD	19
6	PROGRAMMING THE MEMORY	20

7	PRINT MAKING USING THE PROBE	22
7.1	Using the exposure - contrast probe some notes and guidelines	23
8	PROGRAM STRUCTURE	24
8.2	Calibration of the exposure - contrast probe	24
8.2a	Density calibration - 'New Cal' and 'Cal Adj'	24
8.2b	Grade calibration - 'Contrast Adj'	26
8.3	Checking or setting up a grade table	26
9	CLEANING AND MAINTENANCE	28
9.1	Cleaning	28
9.2	Replacing the lamp	28
9.3	Projection lamp - preventative maintenance	29
9.4	Replacing mains input or lamp fuse	29
10	FAULT FINDING	30
11	SPECIFICATION	33
12	PAPER CHANNEL DATA	36

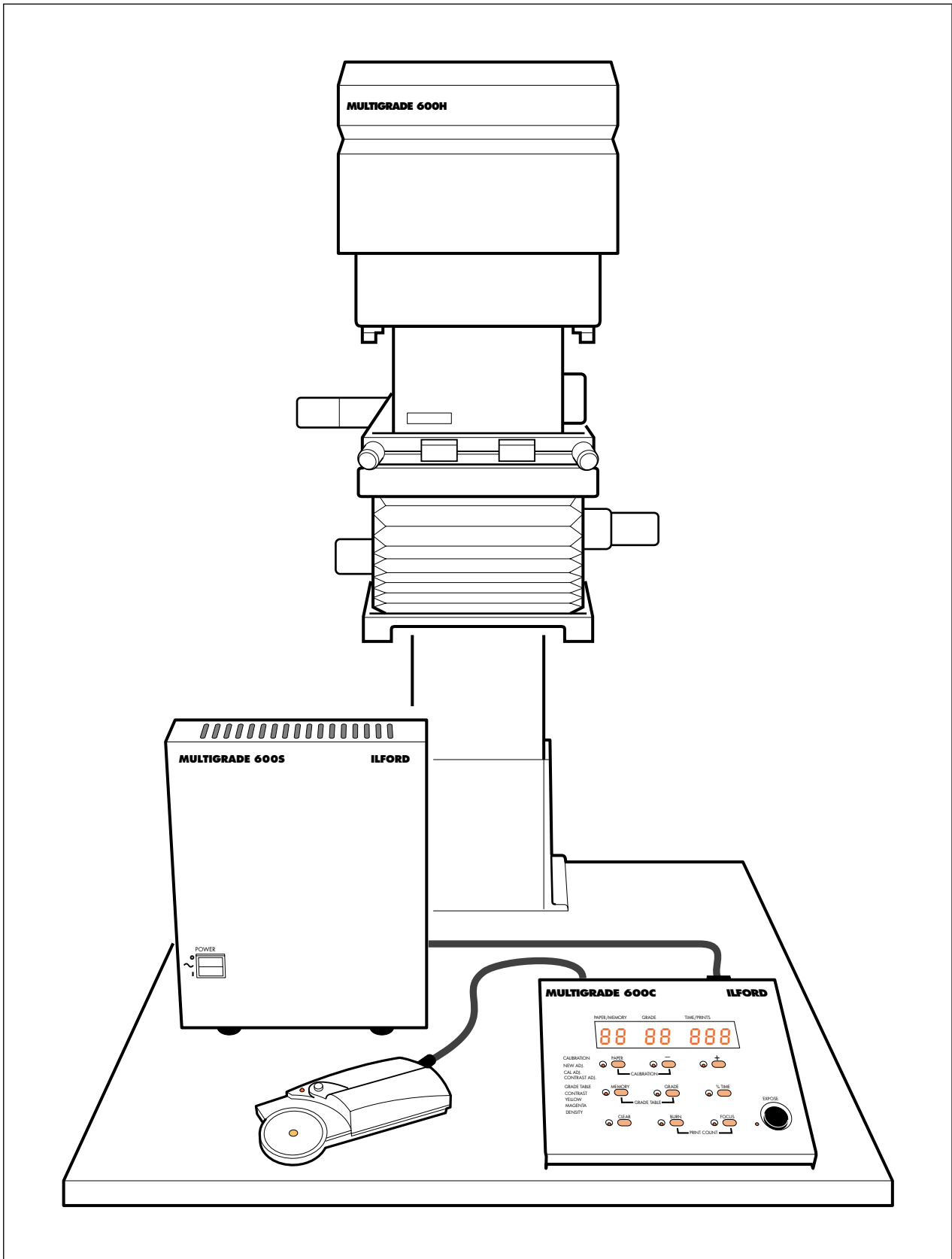

Figure 1.1

MULTIGRADE 600 System

1

INTRODUCTION

See figure 1.1.

The MULTIGRADE 600 enlarger head and control system is for use on professional enlargers where negative coverage is required up to 12.7x10.2cm (5x4 inches). The system incorporates advanced electronics, and offers the black and white printer finger tip control of a wide range of contrasts.

The MULTIGRADE 600 system comprises the following elements:

- a MULTIGRADE 600H enlarger head
- b MULTIGRADE 600C control unit
- c MULTIGRADE 600S power supply
- d MULTIGRADE 600P contrast and exposure probe

1.1 OPTIONAL EXTRAS

Available as optional extras are:

- a A range of light mixing boxes from 35mm up to 5x4inches.
- b MULTIGRADE 600F footswitch

2

DESCRIPTION

The MULTIGRADE 600 system is easy to install and straightforward to use. By following the instructions in this manual, quality prints, together with continuous and reliable operation, are assured.

2.1 MULTIGRADE 600H ENLARGER HEAD

See figure 2.1.

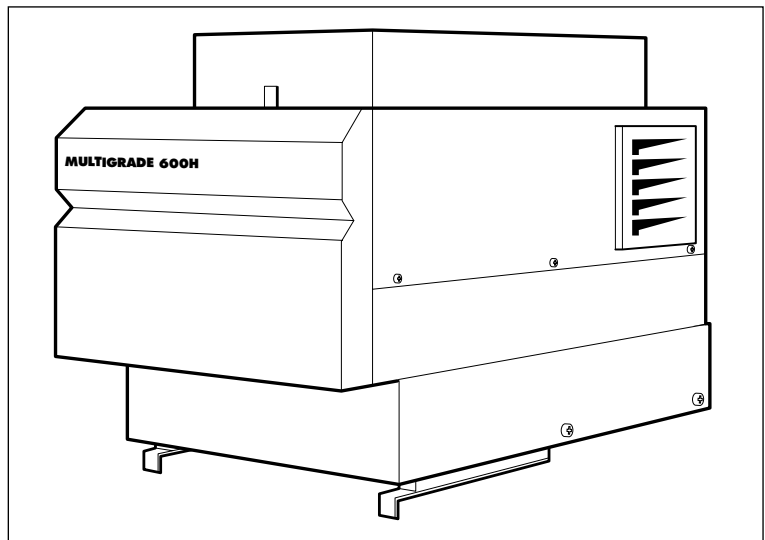

Figure 2.1 MULTIGRADE 600H enlarger head

The MULTIGRADE 600H diffuser enlarger head replaces the original condenser, diffuser or cold cathode lamphouse used with a range of professional enlargers. It is fitted to the enlarger chassis using an adaptor kit, designed to make installation quick and relatively simple.

2.1a Light source

The enlarger head is fitted with a fan cooled high output halogen lamp, heat filter and motorized yellow and magenta dichroic colour filters.

The lamp is kept running at low power (pre-warmed) whenever the system is switched on, to provide quick start-up and consistent results. The cooling fan runs only while an exposure is being made.

Extremely stable and repeatable exposures are provided by a proven closed loop light monitoring system and motorised light shutter mounted in the base of the head, just above the light mixing box. Light from the filters is reflected and diffused in the mixing box to provide even illumination of the negative. The colour variation obtainable enables the wide contrast range, available with ILFORD variable contrast papers, to be used to its full advantage.

Note

A single servo motor drives both filter carriers. At one extreme, the magenta filter is fully in the light beam (Grade 5). At mid-travel, both filters are clear of the light beam and white light is transmitted (at Grade 2.5) giving maximum printing speed. At the other extreme, the yellow filter is fully in the light beam (Grade 00). The yellow and magenta filters can never both be in the light beam at the same time.

2.1b Light mixing boxes

A range of light mixing boxes is available, including sizes 35mm, 6x6cm, 6x7cm, 6x9cm and 5x4inches.

The box or boxes required are not included with the MG600 system and must be ordered separately. Additional boxes may be ordered at any time to suit user requirements.

To fit the light mixing box, see section 4.1a.

2.2 MULTIGRADE 600C CONTROL UNIT

See figure 2.2.

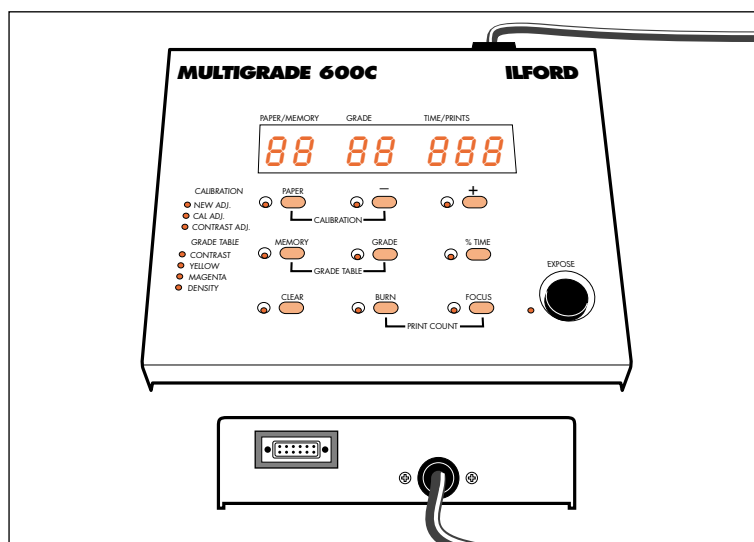

Figure 2.2 MULTIGRADE 600C control unit

The MULTIGRADE 600C control unit is quick and simple to operate. Once the exposure time and contrast are established, the permanent microprocessor controlled closed loop system checks light intensity and colour before each exposure. A correction is made automatically to the exposure time and filtration (if required) to ensure consistent print results time after time.

The control unit provides five paper channels. Four are pre-programmed for ILFORD papers (see section 2.7) and one is left free for programming by the user, if required.

Note

All channels can be checked and/or re-programmed (see section 8).

The control unit also incorporates calibration facilities to ensure that the desired print density and grade are obtained when scanning an image with the probe (see section 8).

All controls are described in section 3.

For maximum operator safety, the control unit is powered entirely by low voltages supplied from a remote power supply (see section 2.3).

The brightness of the display and button indicator lights optimised to be seen under normal darkroom lighting. During normal use, the displays will not fog ILFORD variable contrast papers or other black and white paper of similar sensitivity.

2.3 MULTIGRADE 600S POWER SUPPLY

See figure 2.3.

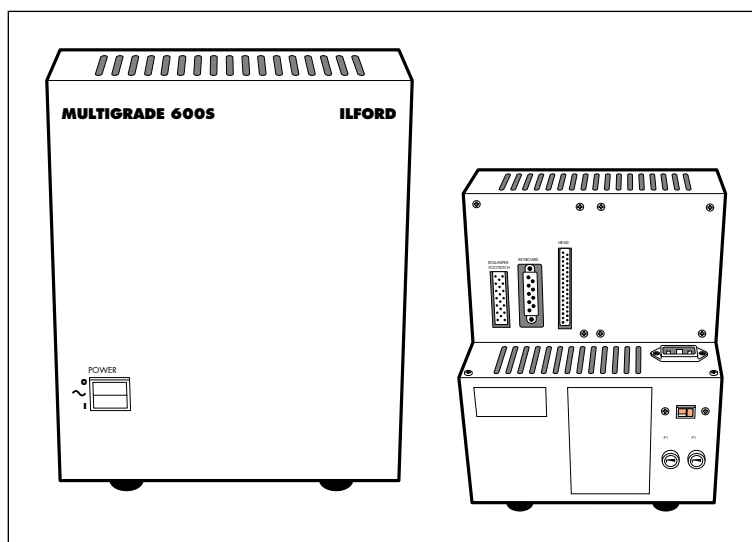

Figure 2.3 MULTIGRADE 600S power supply unit

The MULTIGRADE 600S stabilised power supply is connected directly to the electrical mains supply. It has sockets for connecting the enlarger head, control unit and footswitch or roll easel, positioned on the rear of the unit. The on/off switch, showing 'O' in the off position, controls power to the system.



CAUTION

The unit is factory set to mains voltage of 230V. Before switching on the unit please check the correct mains voltage is selected and the correct fuse is fitted, see section 4.2a.

2.4 MULTIGRADE 600P EXPOSURE PROBE

See figure 2.4.

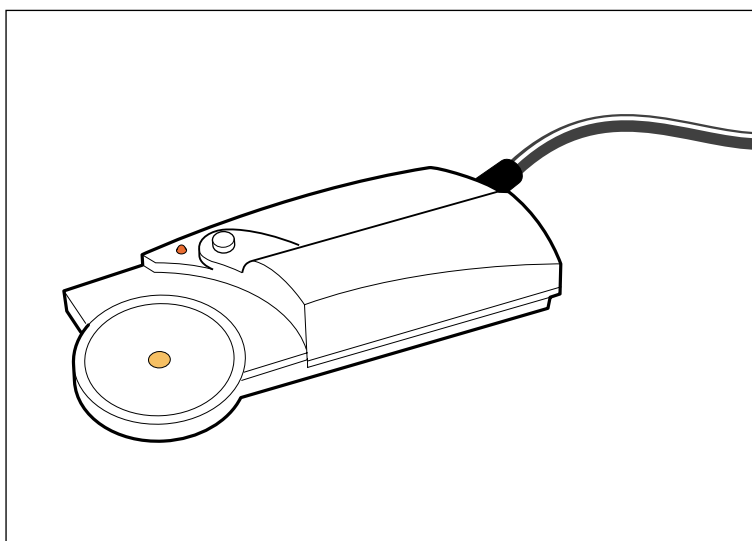

Figure 2.4 MULTIGRADE 600P exposure probe

The MULTIGRADE 600P probe saves paper and time by eliminating the need to make test strips or sheets.

The brightest and darkest parts of the image are scanned and the readings obtained enable exposure time and grade to be automatically calculated and displayed.

For a detailed description of how to use the probe, see section 7.

2.5 MULTIGRADE 600F FOOTSWITCH

The MULTIGRADE 600F footswitch is available as an optional extra, and enables the printer to keep both hands free. The function of the footswitch is to start an exposure only. If an exposure in progress is required to be cancelled, this must be done on the control unit.

2.6 AUTOMATIC ROLL EASEL

The MULTIGRADE 600 system can be connected to most automatic roll easels. Connection is made via an 8-pin Siemens plug (as typically used on Durst roll easels). Please contact ILFORD for inter-connection details.

2.7 PHOTOGRAPHIC PAPERS

The MULTIGRADE 600 system is designed for use with ILFORD MULTIGRADE variable contrast papers.

2.7a MULTIGRADE paper

The control unit is pre-programmed for the following papers:

- P1 ILFORD MULTIGRADE IV RC Deluxe
- P2 ILFORD MULTIGRADE RC Warmtone
- P3 ILFORD MULTIGRADE IV FB Fiber
- P4 ILFORD MULTIGRADE FB Warmtone
- P5 Spare channel

2.7b Other papers

Colour prints or prints from graded papers such as ILFORD ILFOSPEED can be made using an appropriate setting from one of the paper channels (grade 2.5) where both yellow and magenta filtration values are set to zero, ie the enlarger head is projecting white light. See section 12.

Alternatively, if it has not been reprogrammed, any grade setting in paper channel 5 (P5) may be used.

During use, the control unit will display the grade set but this will have no relevance to the prints being made.

3

CONTROLS

See figure 3.1.

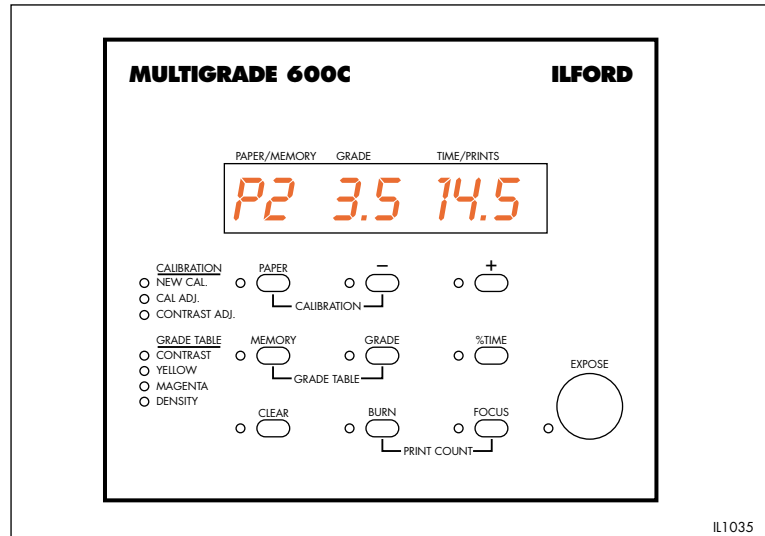
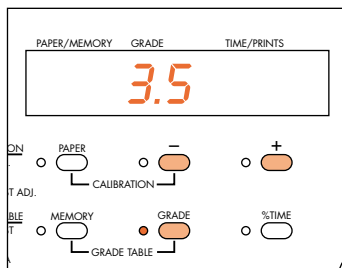

Figure 3.1

Controls

All controls necessary to operate the MULTIGRADE 600 system are located on the control unit, except for the power control switch which is located on the power supply.



3.1 CONTRAST SELECTION

Grade is displayed in the centre display and is set by holding down the 'Grade' button and depressing the +/- buttons to increase or decrease the set value. The buttons control grade selection from 5 (highest grade) to 0.0 (low grade) in 1/10 grade steps. At setting 0.0, a further press of the - button selects the lowest grade 00. Holding the +/- buttons down causes the display to roll sequentially in increments of 1/10 grade.

Note

When making changes to the grade setting, any necessary changes to the exposure time to maintain a constant print density will be automatically set by the control unit.

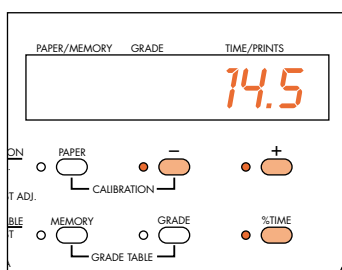

3.2 ELECTRONIC TIMER

Exposure time is displayed in the right hand display. Time is displayed in hundredths of a second for 1.00 to 9.99 seconds, tenths of seconds for 10.0 to 99.9 seconds and in whole seconds from 100 to 999 seconds. The display counts down to zero during main exposures, then resets to the set value. The required exposure time is set using the +/- buttons. A short press will increment the set value. Keeping a button depressed will cause the time to roll up or down. The roll rate increases if the button is held depressed for more than two seconds.

Note

The exposure time cannot be incremented in less than 2% steps. Exposure time may also be adjusted using the '% Time' button. When the '% Time' button is depressed, the time display shows zero. Whilst holding this button depressed, the required percentage time adjustment can be set using the +/- buttons. On release of the '% Time' button, the corrected time is displayed. The operating range of % Time is -99% to +999%.

Note

When an exposure is initiated, the closed loop control system assesses colour and brightness of the exposing light before the shutter is opened to begin the exposure. Any necessary corrections to maintain a constant exposure are made automatically and this could result in the set exposure time changing to a different value, from which the countdown then begins.

This is normal operation for the system. The effect will become more pronounced (an increase in exposure time) as the lamp ages and its light output reduces, or the colour filters become dirty, etc.

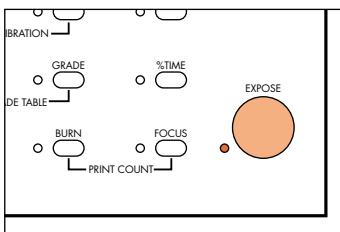

3.3 EXPOSE

With the time and grade selected, start the main exposure by pressing the 'expose' button. The time will count down to zero. Exposure can be stopped at any time by pressing the 'expose' button. Pressing the expose button again will re-start and complete the remaining exposure. If the remaining exposure is not required, pressing the 'clear' button resets the timer to the original exposure time.

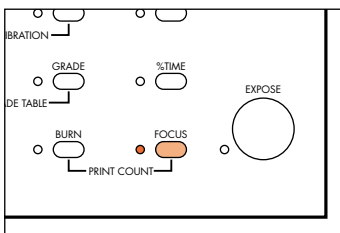

3.4 FOCUS

To obtain a continuous light suitable for focusing and composition, press the 'Focus' button. To cancel the 'Focus' mode, press the 'Focus' button again (or the 'Clear' or 'Expose' buttons).

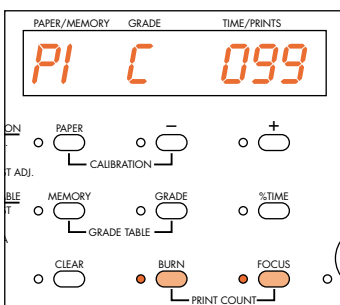

3.5 PRINTS COUNTER

The control unit automatically counts the number of main exposures (additional burn-in exposures are not counted). This is particularly useful if a run of identical prints is made from one negative. To obtain the display, simultaneously press the 'Focus' and 'Burn' buttons. For example, 99 exposure cycles is displayed C 099

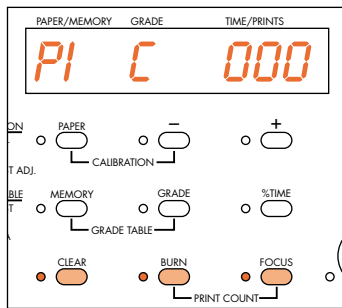

Note

The maximum number of exposure cycles that can be counted is 999.

To reset the prints counter to zero, press and hold the 'Focus' and 'Burn' buttons and press the 'Clear' button also.

Notes

- a The prints counter will also record a cancelled exposure cycle.
- b The print counter retains the count value when power to the unit is switched off. Ensure that the counter is zeroed before starting a new print run.

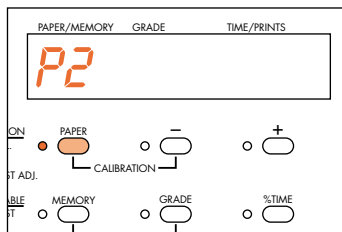

3.6 PAPER CHANNEL SELECTION

The 'Paper' button is used to select paper channels P1 to P5 (see section 2.7). The selection is indicated in the left-hand display.

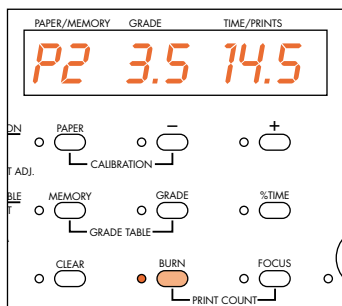

3.7 MANUAL BURNING-IN

The 'Burn' button selects a continuous exposure at the grade shown on the display for manual burning in. If required, the grade can be changed during the exposure.

To cancel the 'Burn' mode, press the 'Burn' button again (or the 'Clear' or 'Expose' buttons).

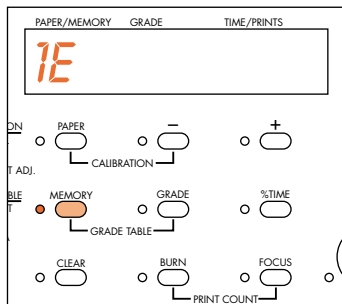

3.8 BURNING-IN OPERATIONS USING THE MEMORY FACILITY

The control unit incorporates a memory store, capable of storing a maximum of three exposures in addition to the main exposure and is selected using the 'Memory' button. The memory store is particularly useful for programming a sequence of additional exposures to follow the main exposure. Each additional exposure can be made at a different grade. Once the memory has been programmed, the control unit steps through the sequence of exposures each time the 'Expose' button is pressed. See section 6.

Note

The stored memories are retained when the equipment is switched off.

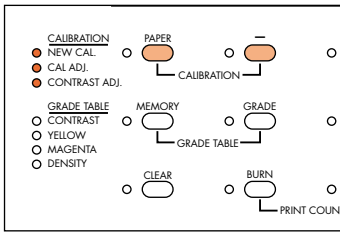

3.9 CALIBRATION

The three functions which may be calibrated or re-calibrated are selected by holding down the 'Paper' button and pressing the '-' button to select the feature required. An LED on the panel illuminates to indicate the feature selected. A fourth press of the '-' button returns the control unit to normal operation. See section 8 for details.

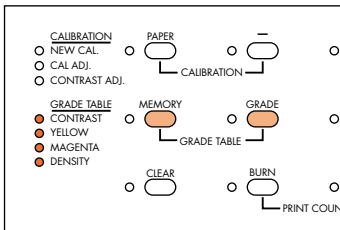

3.10 GRADE TABLE

The four elements of the grade tables may be accessed if the stored data needs to be changed or if Paper channel 5 is required to be set up. For each Paper channel, the data to be checked or changed is selected by holding down the 'memory' button and then pressing the 'Grade' button. An LED on the panel illuminates to indicate the data selected. A fifth press of the 'Grade' button returns the control units to normal operation. See section 8 for details.

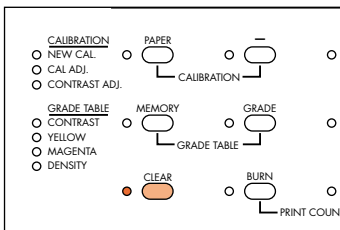

3.11 CLEAR BUTTON

The 'Clear' button is used to:

- Reset a cancelled exposure to its original setting
- Reset the Burn-in memory times (for memories 3E and 4E) to zero.
- Reset the paper grade table data to the factory programmed values values
- Reset the print counter to zero

4

INSTALLATION

See figure 4.2.



CAUTION

Installation of the MULTIGRADE 600 system is very straightforward. However, if you are in any doubt about making any of the electrical connections, consult a competent electrician. Ensure the mains electrical supply is switched off before connecting or disconnecting any plug.

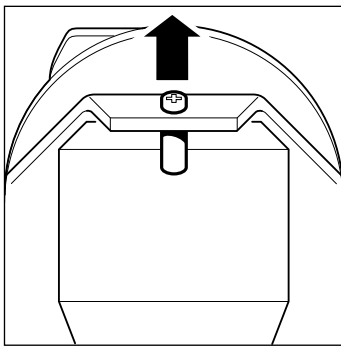

4.1 ENLARGER HEAD

For information on fitting the enlarger head to your particular enlarger, refer to the separate leaflet supplied with the adaptor kit.

During installation, remove the top access cover (see section 9) and remove the transport securing device (screw and bush). Replace the top cover.

Connect the head to the appropriate socket on the power supply.

4.1a Changing light mixing boxes

See figure 4.1.

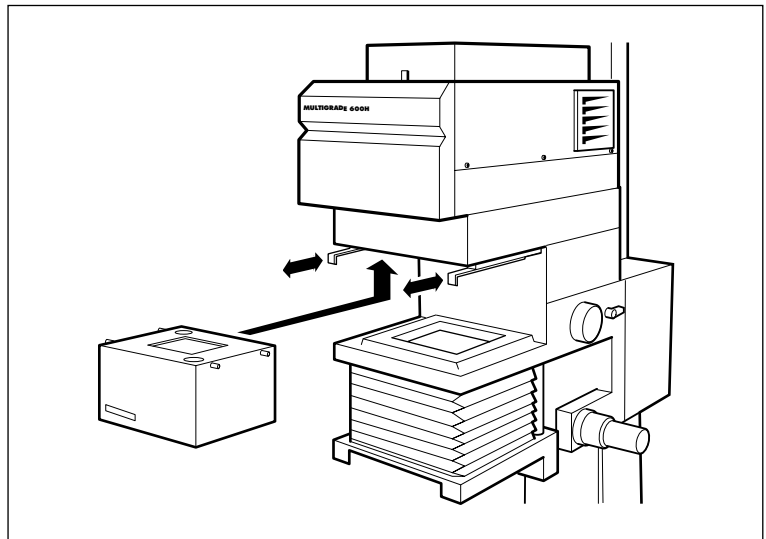

Figure 4.1

Changing light mixing boxes

To minimise exposure times, a light mixing box should be fitted which suits the negative format being printed.

To fit a light mixing box:

- 1 With the negative carrier removed, move the two slide catches, which retain the mixing box, to the forward position.

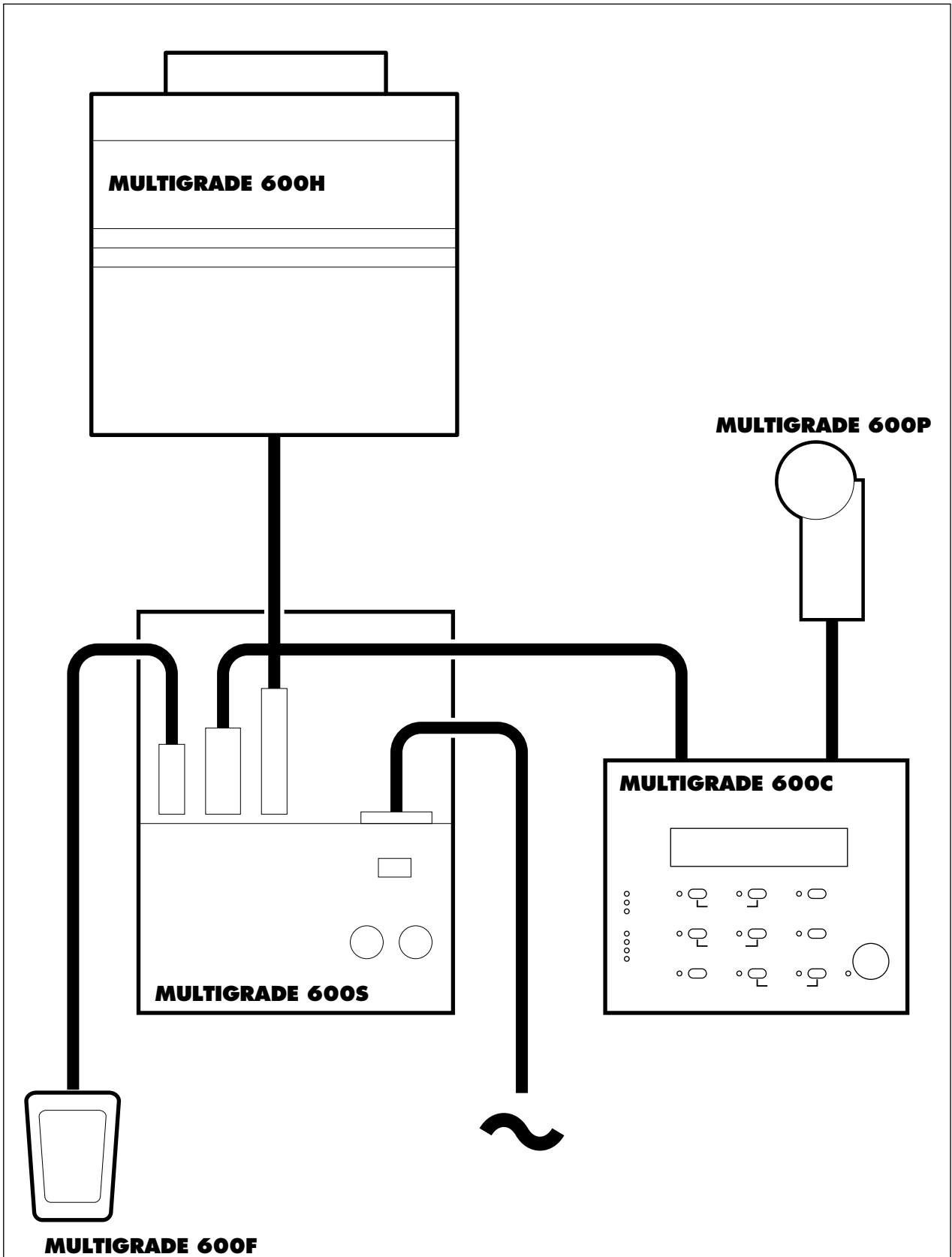

Figure 4.2

Installation

- 2 Ensure the mixing box format/size label is facing the front (eg 24x36mm).
- 3 Locate the mixing box in position and lift upward to locate the retaining pins into their slots.
- 4 Move both slide catches backward to lock the mixing box in position.
- 5 Refit the negative carrier.

Removal of the mixing box is the reverse of the above procedure. Support the mixing box to prevent it from dropping downwards as the slide catches are released.

4.2 POWER SUPPLY

4.2a Supply voltage



WARNING

The power supply is supplied with the voltage selector set to 230V and a 2.5A fuse fitted. Before switching on, check that this is correct for your electrical mains supply. If it is not, carry out the following procedure.

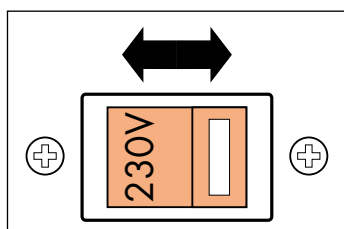

- 1 Remove the bayonet fitting fuseholder cap, complete with fuse (F1).
- 2 A two position supply voltage selector is located on the rear panel enabling the appropriate input voltage to be selected in accordance with the electrical mains supply.

Position the 2-position voltage selector to the correct setting.

- a For supplies 110-120V, 50/60Hz, set to the 115V position.
 - b For supplies 220-240V, 50/60Hz, set to the 230V position.
- 3 Fit the correct fuse, supplied with the unit (see section 11).
 - a For 115V insert T-5.0A fuse.
 - b For 230V insert T-2.5A fuse.

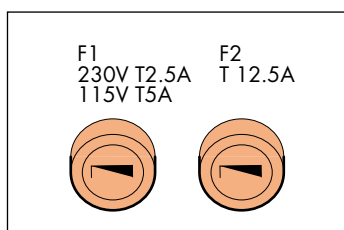

4.2b Working environment

The power supply is totally enclosed and becomes warm with extended use. It is advisable to position the unit so that adequate all round ventilation is provided at all times.



CAUTION

For safety reasons, do not position the power supply on the floor. When the power supply had been positioned, ensure there is enough slack in the lead to the enlarger head, to allow full travel of the head on the enlarger column.

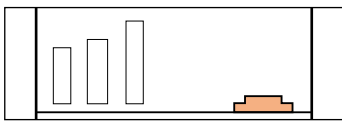

4.2c Connection to mains supply

If a moulded plug is not fitted to the mains cable provided, connect a plug of at least 10A rating as follows:

- Brown wire to the live pin (marked L).
- Blue wire to the neutral pin (marked N).
- Green/yellow wire to the earth pin (marked E or \perp).

Connect the other end of the mains cable to the 'power input' socket on the power supply. Ensure the plug is pushed fully into the socket.

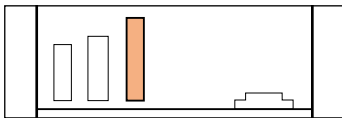

4.3 ENLARGER HEAD

Connect the enlarger head to the appropriate socket on the power supply.

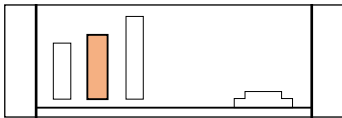

4.4 CONTROL UNIT

Connect the control unit lead to the appropriate socket on the power supply, and tighten the two retaining screws.

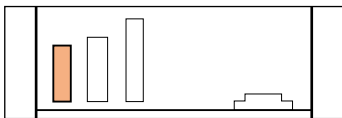

4.5 FOOTSWITCH

Connect the footswitch to the appropriate socket on the power supply.

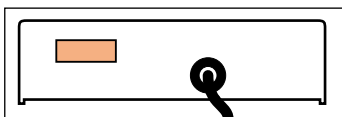

4.6 EXPOSURE PROBE

Connect the probe to the appropriate socket on the control unit, and tighten the two retaining screws.

5

PRINT MAKING STANDARD METHOD

- 1 Switch the system on.

Note

The control unit will display the values set when it was last switched off. Select the required paper channel for the paper type you are using.

- 2 Locate your negative in the enlarger. Select 'Focus' to project white light for focusing, composition and assessment of the image. When satisfied press 'Focus' again to cancel.
- 3 Select the contrast required. See section 3.1.
- 4 Select the estimated exposure time. See section 3.2.
- 5 Position a sheet of ILFORD MULTIGRADE paper on the enlarger base board. Expose the sheet by pressing 'expose'.
- 6 Process the exposed paper. Check the print for density. If necessary, correct the exposure and make another print.
- 7 Check the print for contrast. If necessary, make another print at a different grade.

It is not necessary to alter the exposure time when changing grades. This is done automatically by the control unit to ensure that a constant mid-tone density is maintained.

6

PROGRAMMING THE MEMORY

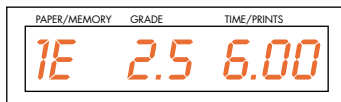
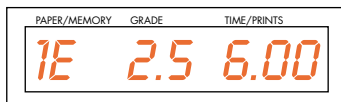
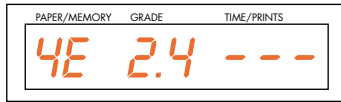
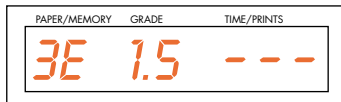
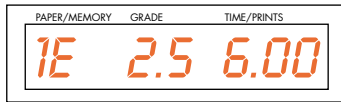
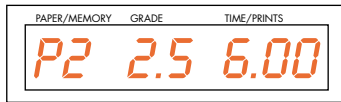

- 1 The values shown in the following diagrams are given for example only. Set the paper channel main exposure time and grade required in the normal way.
- 2 Press 'memory'. '1E' will appear in the memory display indicating that the control unit is now in memory mode. The exposure time and grade set above have now become the main exposure 1E, to be followed by burn-in exposures 2E, 3E and 4E.
- 3 Press 'memory' again and '2E' will appear in the memory display. As a start point, this second exposure always sets to 50% of the main exposure (at the grade setting previously left in the memory).
- 4 Reset the exposure time and grade to the settings required for the second exposure (first burn-in memory).
- 5 Press 'memory' again to select the third exposure. The last grade value used will appear in the display. An exposure time may appear if it was not previously cleared.
- 6 Set the exposure time and grade to the settings required for the third exposure.
- 7 Repeat 5 and 6 to set the fourth exposure if required. If not required, cancel the exposure time by pressing 'Clear'.

Note

The control unit will ignore exposures 3E and 4E when the exposure time is set to '---'.

- 8 A further press of the 'memory' button will return the control unit to normal mode, where only this exposure will be activated on pressing 'Expose'.
- 9 To use the burn-in memories set as above, again press 'memory' so that 1E is shown in the display. Pressing 'Expose' now will cause the control unit to step sequentially through the exposures.

Notes

- a The burn-in memories are retained in the memory unless cancelled or reset.
- b The exposure time of memory 2E cannot be set to '— —'. If only the main exposure is required, set the control unit back to normal mode with a paper channel showing in the display.
- c If the main exposure time is reset (when either set to a paper channel or to '1E') then the times set in all memories will be reset in the same ratio. The grade settings are unaffected.

If any recalculated exposure time is less than 1.0 seconds, the value will be displayed but will flash indicating that this exposure cannot be made.

- d Pressing '% Time' when the display is showing memories 2E, 3E or 4E indicates the burn-in exposure as a percentage of the main exposure 1E.

7

PRINT MAKING USING THE PROBE

See figure 7.1.

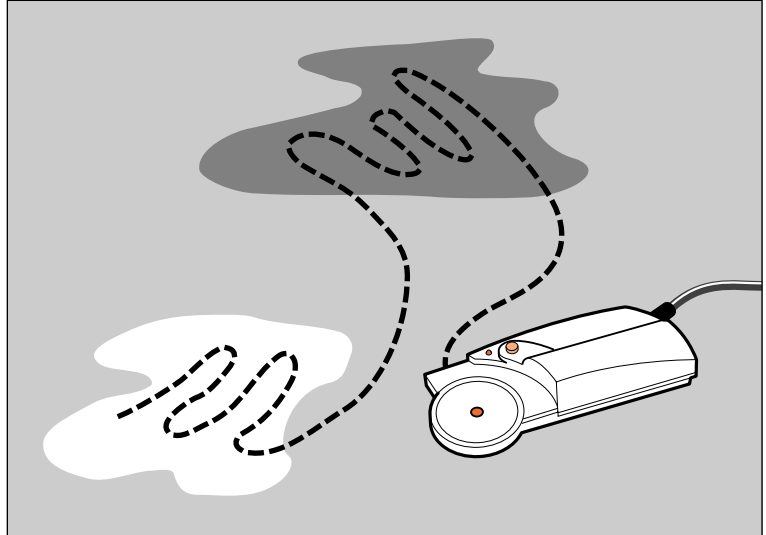

Figure 7.1 Using the MG600 exposure probe

- 1 Insert the negative to be printed into the enlarger. Select 'Focus'. Focus and compose the required image and set the working aperture (f-stop) of the lens.

Select the appropriate paper channel on the control unit.

- 2 Check the probe LED is switched on. Position the probe photocell in the brightest area of the projected image and press and hold the probe button.

Note

The probe button must be held down during the complete measurement cycle.

- 3 When the probe LED extinguishes move the probe measuring cell over the brightest and darkest areas of the image. Release the probe button.
- 4 The calculated exposure time and grade is then displayed. Unless you wish to make a further measurement, cancel the focus light and prepare to make a print.
- 5 Position a sheet of paper on the enlarger baseboard. Press 'expose'. The sheet is given the calculated exposure. Process and assess the final print.
- 6 The exposure probe can be used if the control unit has stored memories.

Note

The exposure times set in the burn-in memories will be modified in the same ratio as the new and previous main exposure times. The grades set in the memories are unaffected (see section 6 Note c).

7.1 USING THE EXPOSURE-CONTRAST PROBE SOME NOTES AND GUIDELINES

If used correctly, the MULTIGRADE 600P exposure probe can be of great benefit to the black and white printer. Listed below are some simple rules to observe in order to maximise the probe accuracy.

- 1 Pressing the probe button opens a shutter covering the measuring cell and begins the measuring cycle.
- 2 During scanning, the probe takes ten readings per second. The highest and lowest readings are stored and enable the grade and exposure time to be calculated.
- 3 Also during scanning, the display shows the previously set grade and a number which represents the density being measured by the probe. This enables the lightest and darkest areas of the image to be found (if necessary). The difference between the highest and lowest numbers represents the contrast of the negative.

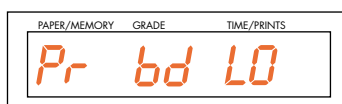
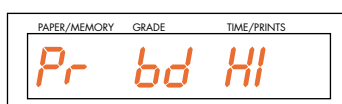
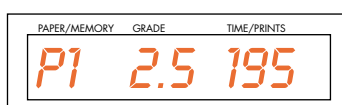

- 4 If the light level measured is too low, the display will show Pr bd HI (Probe density high). The lens aperture should be increased and a new probe measurement taken.

If the light level is too high, the display will show Pr bd LO (Probe density low). The lens aperture should be reduced and a new probe measurement taken.

- 5 The probe is not affected by normal levels of darkroom safelighting. However a very bright safelight situated close to and above the enlarger baseboard could have an effect. This can easily be checked. Operate the probe button to initiate a probe measurement. View the density value being displayed on the control unit (see 7.1 para 3 above) and switch the local safelight on and off. If the number displayed is affected, then for accurate results, this safelight should be re-sited or switched off when using the probe.
- 6 If the paper channel is changed, the image must be measured again for accurate results.
- 7 Obtaining good results with the probe requires some familiarisation with its use. It is not necessarily the absolute brightest and darkest parts of the image which should be scanned, but rather the areas in which detail still needs to be seen in the resulting print. Extreme dark areas or highlights should therefore be avoided when scanning.
- 8 The MULTIGRADE 600 system is programmed to calculate the correct exposure time for a wide range of negatives. Inevitably, there will be some negatives (showing extremes of exposure or development or not having a suitable area from which to take readings) that may produce inaccurate results. If continued difficulty is found in obtaining a high percentage of correctly exposed prints, the probe may be re-calibrated (see section 8).

PROGRAM STRUCTURE

8.1 BASIC CALIBRATION AND DATA ENTRY

The program consists of five paper channels, each with the following structure:

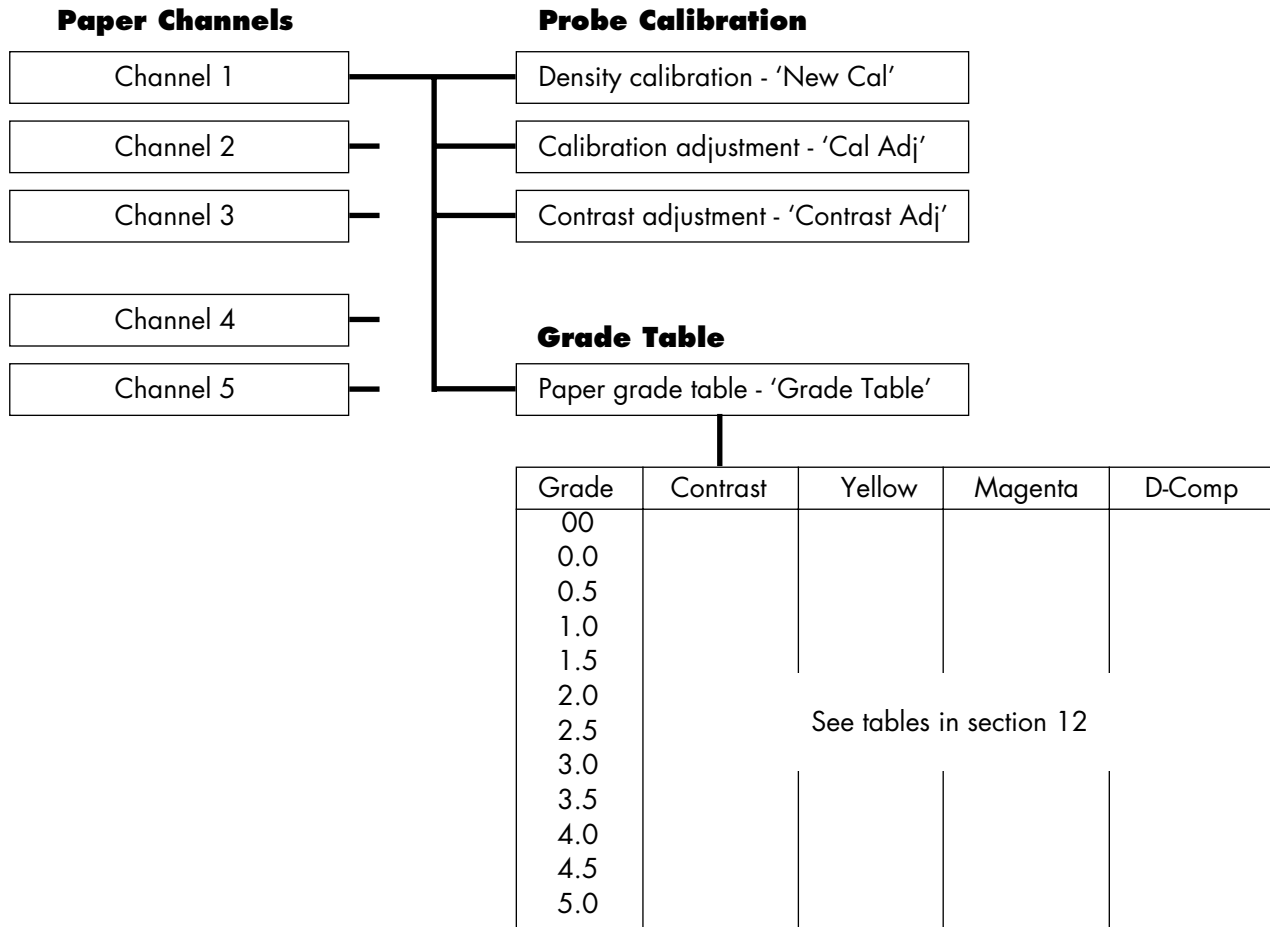

8.2 CALIBRATION OF THE EXPOSURE-CONTRAST PROBE

The 'Calibration' function allows the basic setting up of the system to obtain the correct exposure times (density) and grade, when using the probe.

8.2a Density calibration - 'New Cal' and 'Cal Adj'

The density calibration factor 'Cal' is displayed on the control unit in 'Cal Adj' mode. The value of 'Cal' is determined by making test prints and is directly linked to exposure time determined by the probe (it represents paper speed).

'New Cal' should be used to calibrate the probe for new batches of paper. 'Cal Adj' is best used to reset the calibration to predetermined values. For example, to reset to values determined under 'New Cal' and then written on the paper box for reference.

Fine tuning can also be carried out by small adjustments of the 'New Cal' value to compensate for a drift in processing chemistry activity, for example.

Density calibration is only possible by using the following procedure, during which a probe measurement must be made when the control unit displays 'Measure'.

To calibrate proceed as follows:

Select an average production negative of good tonal range which you would expect to be printed at grade 2.5 and place in the enlarger. Press 'Focus', adjust and focus an image of approximately 20x25cm (8x10in) onto the baseboard. Set the working aperture on the lens.

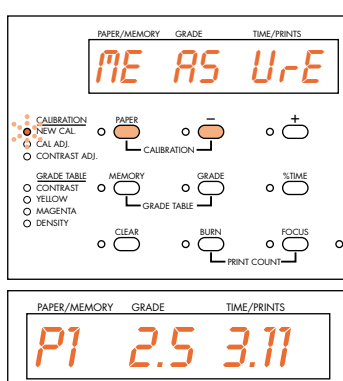

- 1 Select the paper channel.
- 2 Select 'New Cal' mode by keeping the 'Paper' button depressed and by pressing the '-' button once.
- 3 The 'New Cal' LED will light up and the display will show 'Measure'.
- 4 With the room lights off, make a normal probe measurement (see section 7). After releasing the probe key, the display will show the grade (2.5) and the exposure time (which corresponds to the calibration value).
- 5 Make an exposure with the settings obtained and process the print.
- 6 Correct the test print by adjusting the exposure time using the '+/-' buttons as required.

Note

When the exposure time is corrected, the calibration value will be automatically adjusted (they are directly linked together).

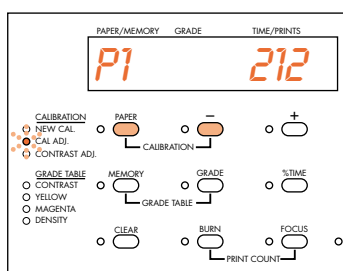

- 7 Repeat steps 5 and 6 until the density of the test print is correct.
- 8 Select 'Cal Adj' by keeping the 'Paper' button depressed and pressing the '-' button once.
- 9 The 'Cal Adj' LED will light and the display will show the calibration value derived during the previous procedure. This calibration value represents the paper speed and for reference should be noted down or written on the box of paper being used.
- 10 Return to the normal printing mode by keeping the 'Paper' button depressed and by pressing the '+/-' button twice.
- 11 If required, the density calibration value may be adjusted in 'Cal Adj' mode by using the '+/-' buttons. 30 units corresponds to 1 f-stop (eg. reducing the calibration value by 30 will halve the exposure time set).

Note

Changing the value in 'Cal Adj' only changes the exposure times determined by the probe.

8.2b Grade calibration - 'Contrast Adj'

This function allows the grade (contrast) value determined by the probe to be offset by $\pm 30\%$ (an adjustment of approximately ± 1.5 grades). It also enables personal taste to be taken into account and can provide matching between two batches of paper.

A change to 'Contrast Adj' results in a print contrast being obtained which is either higher or lower than the value determined by the grade table. The grade correction function only fully affects the grade values (as determined by the probe) in the range 1.0 to 4.0.

The available offset from 1.0 towards 0.0 and from 4.0 towards 5.0, reduces as the extremes of the range are approached.

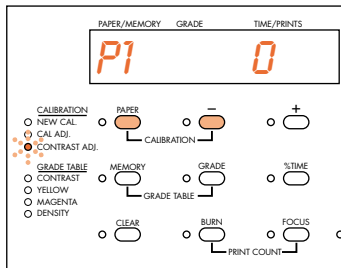

- 1 Select 'Contrast Adj' mode by keeping the 'Paper' button depressed and by pressing the '-' button twice.
- 2 The 'Contrast Adj' LED will light and the display will show the contrast correction value in %. This will be 0 if no previous correction has been made.
- 3 The correction value can be set from -30 to $+30$ using the $+/-$ buttons. + increases the contrast - lowers the contrast
- 4 Return to normal printing mode by keeping the 'Paper' button depressed and pressing the '-' button.

After switching to the normal printing mode, the system automatically re-calculates the grade and exposure time determined by the probe during calibration mode.

- 5 Whenever required, the contrast calibration value may be adjusted in 'Contrast Adj' mode by using the $+/-$ buttons.

8.3 CHECKING OR SETTING UP A GRADE TABLE

The following example shows the procedure for setting or checking data in a grade table. Values shown in this example are from the table for channel 1 (see section 12).

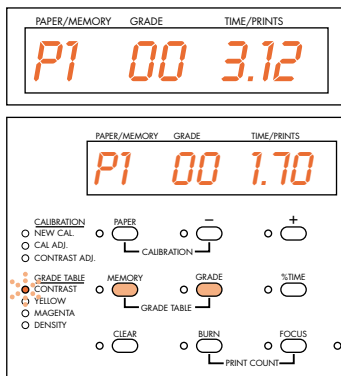

- 1 Select the paper channel.
- 2 Call up the grade table by keeping the 'Memory' button depressed and by pressing the 'Grade' button once.
- 3 The 'Contrast' LED will light and the display will show the paper grade and the corresponding set value for the contrast (1st and 2nd columns in the grade table)
- 3a Adjust the contrast value by pressing the $+/-$ buttons.

Notes

The actual grade achieved on the print is determined by the settings of the yellow and magenta filters. The contrast value

shown in the table enables the probe to calculate the correct grade following measurements taken during a scanning cycle.

The contrast value can only be adjusted over a limited range, pre-determined by the control unit, otherwise 'Cont Err' will be displayed when the unit is returned to normal operating mode.

3b Change to the next paper grade step by pressing the 'Grade' button.

3c Repeat the above steps until you have adjusted or checked the values for all paper grade steps (00 - 5.0)

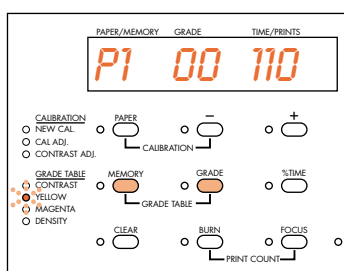

4 Now change to the entering mode for the Yellow-filtration by keeping the 'Memory' button depressed and by pressing the 'Grade' button. The 'Yellow' LED will light and the display will show the paper grade and the corresponding set value for the Yellow-filtration. (1st and 3rd columns in the grade table)

4a Adjust the Yellow-filtration by pressing the '+/-' buttons.

4b Step through the paper grades by pressing the 'Grade' button as before.

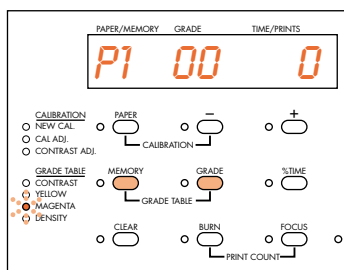

5 Now change to the entering mode for the Magenta-filtration by keeping the 'Memory' button depressed and by pressing the 'Grade' button. The 'Magenta' LED will light and the display will show the paper grade and the corresponding set value for the Magenta filtration. (1st and 4th columns in the grade table)

5a Adjust the Magenta-filtration by pressing the '+/-' buttons.

5b Again, step through the grades using the 'Grade' button.

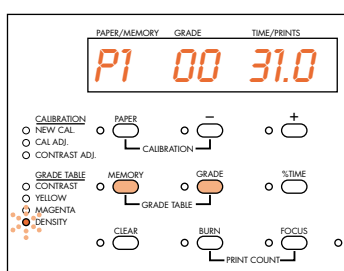

6 Now change to the entering mode for the density compensation by keeping the 'Memory' button depressed and by pressing the 'Grade' button. The 'Density' LED will light and the display will show the paper grade and the corresponding set value for the density compensation, 'D-Comp'. 'D-Comp' enables automatic re-calculation of the exposure time when changing grades to ensure a constant print density. (1st and 5th columns in the grade table)

6a Adjust the value for the 'D-Comp' by pressing the '+/-' buttons. For example, +30 'D-Comp' would double the exposure time from say 2.5 to 5.0 seconds. Note that the value of 0.00 corresponding to grade 2.5 cannot be amended. Step through each grade as before.

6b The checking or entering cycle for the grade table is now complete.

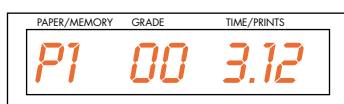

7 To return to the normal printing mode keep the 'Memory' button depressed and press the 'Grade' button.

Note

When contrast, yellow, magenta or D-Comp mode has been selected on the control unit (for checking or changing the set values), pressing the 'Clear' button will return **ALL** values in that column of the table to the factory settings.

CLEANING AND MAINTENANCE



WARNING

Switch off and disconnect the MG600 system from the mains supply before carrying out any cleaning or maintenance procedures.

Never allow liquids to enter the equipment and do not use corrosive cleaning agents.

9.1 CLEANING

Cleaning is the only routine maintenance required on the MULTIGRADE 600 equipment. Carry out the following operations at regular intervals:

- 1 Remove dust and debris from the light mixing box (es) with a soft brush. Take care not to leave fingerprints on the diffuser and internal mirrors.
- 2 The control unit switch panel should be cleaned periodically using a damp, lint free cloth.
- 3 It is recommended that the dust filter on the rear of the MG600H enlarger head is cleaned once per month. Remove and clean in warm water. Dry thoroughly before re-fitting.

9.2 REPLACING THE LAMP

See figure 9.1.

Figure 9.1

- 1 Hinged lamphouse cover
- 2 Lamp clip
- 3 Lamp
- 4 Top cover catch housing

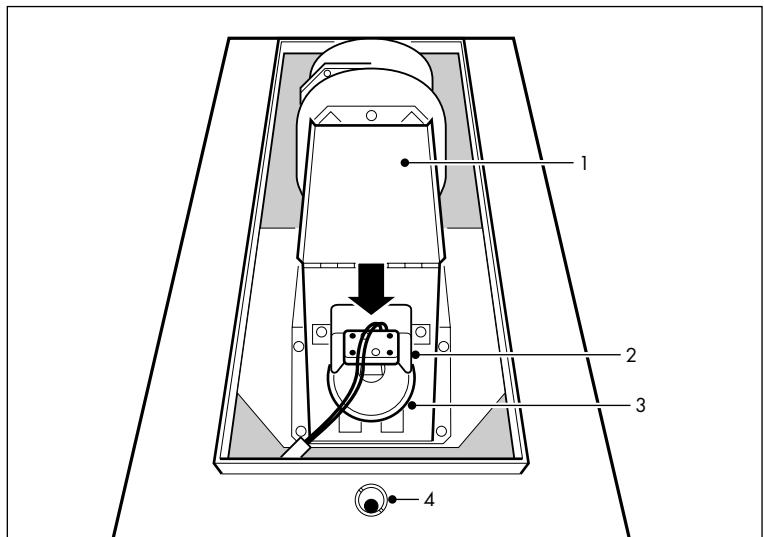

Figure 9.1

Lamp removal and replacement



WARNING

Switch the system off and allow the lamp to cool before handling.

To replace the lamp, proceed as follows:

- 1 Lower the enlarger head for ease of access.
- 2 Press in the sprung catch on the front of the top cover to release.
- 3 Lift the cover up and back and remove from the enlarger head.
- 4 Lift up the hinged cover above the lamp.
- 5 Pull off the lamp socket from the lamp pins.
- 6 Pull the lamp upwards and forwards to disengage it from its locating recess and the springs which retain it in place.
- 7 Fit the new lamp, ensuring that it is properly located.
- 8 Re-connect the lamp socket and close the hinged cover.
- 9 Refit the top cover and press the sprung catch to re-engage.

9.3 PROJECTION LAMP - PREVENTIVE MAINTENANCE

To ensure maximum lamp life and to obtain the best results from the lamp, always keep the following points in mind.

- 1 Do not touch the inner reflective surface of the lamp, and especially the bulb.
- 2 Ensure the correct type lamp is used (see section 1.1 MULTIGRADE 600H enlarger head).
- 3 Avoid excessive vibration and mechanical shock, particularly when the unit is switched on.
- 4 Ensure the power supply is always operated at the correct voltage. Unusually high voltages will reduce lamp performance leading to premature lamp failure.
- 5 Ensure the cooling fan operates correctly, and that the air flow is not obstructed.

9.4 REPLACING MAINS INPUT OR LAMP FUSES

See section 4.2a.

10

FAULT FINDING

This section provides a list of checks to make should there be any problems with the equipment; any competent person can make these checks. If the checks prove to be ineffective, contact your nearest ILFORD Selling Company, the address can be found on the back of this manual.



CAUTION

If in doubt about making any of the following checks, consult a competent engineer. Any further repair work carried out by unqualified personnel will invalidate any guarantees applicable to the equipment.

Symptom	Possible cause	Remedy
1 Display shows LA MP Err	MULTIGRADE 600H	
	Lamp defective or blown or contact poor.	Check lamp (see section 9.2). and lampholder.
	Lamp fuse blown	Check/replace.
	Enlarger head plug not properly located into socket on power supply.	Check connection.
2 Uneven illumination on the enlarger baseboard	Light mixing box damaged or dirty.	Examine for damage. Clean the light mixing box (see section 9.1).
3 Change in print density with change in contrast selection.	Incorrect paper program selected on control unit.	Select alternative program (see section 6)
4 Lamp contacts black or pitted	Defective lampholder.	Replace lamp and lampholder. Contact your nearest ILFORD Selling Company.

Symptom	Possible cause	Remedy
---------	----------------	--------

MULTIGRADE 600C

1	Display and keypad fail to illuminate	Failure of power supply. Poor connection between power supply and control unit.	Check control unit is plugged correctly into the power supply.
2	Flashing 'Time/Prints' display	Calculated exposure times which are less than 1.0 second are shown but with a flashing display (Exposures of less than 1.0 second cannot be made).	Repeat probe reading or re-enter data.
		Calculated exposure times which are greater than 999 seconds are shown as 999, but with a flashing display.	Repeat probe reading or re-enter data.
3	Cont Err	An unrealistic contrast value has been set in the grade table for the paper grade required.	Check the paper/grade table and re-enter revised values as necessary or select 'Contrast' and press 'Clear' to reset the factory settings.

Note

Pressing 'Clear' will set **all** contrast values in the table for that paper channel back to the factory settings.

MULTIGRADE 600S

1	No power to output sockets	Poor connection between electrical mains and power supply.	Ensure plug at each end of mains cable is pushed fully into socket.
		Fuse blown in power supply.	Replace fuse (see section 2.3)
2	Fuse blown	Incorrect fuse fitted.	Check and replace fuse (see section 2.3). If the fault persists, contact your nearest ILFORD Selling Company.
		Incorrect voltage selection.	Check setting on voltage selector and alter if necessary (see section 2.3a).
		Faulty power supply.	Contact your nearest ILFORD Selling Company.

Symptom	Possible cause	Remedy
MULTIGRADE 600P		
1 Display shows Printed HI	Light intensity too low for probe to measure.	Open enlarger lens aperture and repeat measurement.
2 Display shows Printed LO	Light intensity too high for probe to measure.	Close enlarger lens aperture and repeat measurement.
3 Incorrect or erratic results	Incorrect paper channel selected.	Select correct channel.
	Unsuitable areas on projected image chosen to take measurements.	Select areas towards the centre of the projected image if possible and re-measure (see section 7.1).
	Unsuitable negative.	Negatives should be correctly exposed and processed with a good tonal range (see section 7.1). Some negatives, for example, those used in electron microscopy, may be unsuitable for taking probe measurements.
	Very bright safelight close to and above the enlarger.	Move or switch off the safelight. (see section 7.1).

11

SPECIFICATION

MULTIGRADE 600H ENLARGER HEAD

Dimensions	Height 300mm Width 225mm Depth 390mm
Weight	7.45kg excluding light mixing box and adaptor kit
Electrical cable (integral)	Screened Multicore, Length 1.7m connects to MULTIGRADE 600S power supply
Lamp	24V 250W ANSI code ELC Quartz halogen projection lamp with dichroic reflector
Heat filter	35x35x2mm heat absorbing glass
Colour filters	Motorised yellow and magenta dichroic interference filter coatings on glass substrate, each providing maximum obtainable filter density of 170 densitometric units. Cut-off wavelengths selected to give optimum grade range on ILFORD variable contrast papers. Proven automatic closed loop control system providing extremely consistent exposures.
Cooling fan	Dynamically balanced centrifugal type on isolated mountings.
Light mixing boxes	Up to three sizes are available to cover the following negative sizes: up to 35mm, from 35mm to 6x7cm or 6x9cm and from 6x7cm to 4x5 inches.
Evenness of illumination (at f8)	Maximum fall off middle-corners 20% Maximum difference corner-corner 5%

MULTIGRADE 600C CONTROL UNIT

Dimensions	Height 65mm Width 200mm Depth 215mm
Weight	1.84Kg
Electrical cable	Screened Multicore, Length 1.9m connects to the MULTIGRADE 600S power supply unit
Other connections	Socket for exposure-contrast probe.

Features	<p>Operation of each feature is by a push button, with adjacent illuminated indicator.</p> <p>Exposure time 1.0 - 999 sec</p> <p>% exposure time correction -99% to +999%</p> <p>Grade range 00-5 in 1/10 grade steps</p> <p>Paper channels 5. All channels are user programmable</p> <p>Factory settings are provided as follows:</p> <p>P1 ILFORD MULTIGRADE IV RC Deluxe</p> <p>P2 ILFORD MULTIGRADE RC Warmtone</p> <p>P3 ILFORD MULTIGRADE IV FB Fiber</p> <p>P4 ILFORD MULTIGRADE FB Warmtone</p> <p>P5 Spare channel</p> <p>Probe calibration for density and contrast</p> <p>Memory - for storage of 1 main exposure and up to 3 additional exposures.</p> <p>Burn</p> <p>Print counter</p> <p>Focus (white light)</p> <p>Clear</p> <p>Expose - pause</p>
Display	Digital, 7 segment LED's
Electronics	Microprocessor incorporating memory with battery back-up
	MULTIGRADE 600S POWER SUPPLY
Dimensions	Height 280mm Width 220mm Depth 150mm
Weight	11.13Kg
Mains electrical cable (separate)	3 core, live, neutral and earth. Length - 2m
Mains input	Nominal voltage 115/230Vac Frequency 50 or 60Hz Power consumption 400W maximum
Mains Voltage tolerance	-10% to +10%
Replacement fuses - Mains input (F1)	115V T-5.0A (5.0A SB) 230V T-2.5A (2.5A SB) Above fuses are time delay type.
Replacement fuse - Lamp (F2)	250V T-12.5A (12.5A SB)

Outputs	Control unit Enlarger head Footswitch/Roll Easel
---------	--

MULTIGRADE 600P EXPOSURE PROBE

Dimensions	Height 35mm Width 78mm Depth 154mm
------------	--

Weight	0.19Kg
--------	--------

Electrical cable	Screened Multicore, length 1.35m connects to MULTIGRADE 600C control unit
------------------	--

Controls	Measurement period defined by push and release of button Density (exposure time) and contrast (grade) calibration via the MULTIGRADE 600C control unit
----------	--

Reading point	7.5mm diameter, photocell with built-in shutter
---------------	---

GENERAL

Ambient temperature range	15-30°C
---------------------------	---------

Relative Humidity	5-95%
-------------------	-------

Noise Level	56db(A)
-------------	---------

System Weight	Approximately 20Kg
---------------	--------------------

12

PAPER CHANNEL DATA

P1 MULTIGRADE IV RC Deluxe

Gradation	Contrast	Yellow	Magenta	D-Comp
00	1.70	110	0	31.0
0.0	1.50	80	0	26.0
0.5	1.40	65	0	23.0
1.0	1.30	50	0	19.0
1.5	1.20	35	0	13.5
2.0	1.10	20	0	7.00
2.5	1.00	0	15	0.00
3.0	0.90	0	30	5.00
3.5	0.80	0	50	11.0
4.0	0.70	0	70	15.5
4.5	0.60	0	95	19.0
5.0	0.50	0	170	22.5

P2 MULTIGRADE RC Warmtone

Gradation	Contrast	Yellow	Magenta	D-Comp
00	1.70	110	0	29.5
0.0	1.50	80	0	26.0
0.5	1.40	64	0	24.5
1.0	1.30	51	0	21.5
1.5	1.20	36	0	17.0
2.0	1.10	19	0	11.0
2.5	1.00	0	0	0.00
3.0	0.90	0	22	13.0
3.5	0.80	0	43	22.5
4.0	0.70	0	62	28.5
4.5	0.60	0	87	34.0
5.0	0.50	0	170	39.0

P3 MULTIGRADE IV FB Fiber

Gradation	Contrast	Yellow	Magenta	D-Comp
00	1.60	110	0	35.0
0.0	1.50	93	0	34.0
0.5	1.40	73	0	30.0
1.0	1.30	54	0	25.0
1.5	1.20	35	0	16.0
2.0	1.10	16	0	9.00
2.5	1.00	0	0	0.00
3.0	0.90	0	24	7.00
3.5	0.80	0	39	10.0
4.0	0.70	0	54	13.0
4.5	0.60	0	74	17.0
5.0	0.50	0	170	26.0

P4 MULTIGRADE FB Warmtone

Gradation	Contrast	Yellow	Magenta	D-Comp
00	1.60	92	0	15.0
0.0	1.50	70	0	13.0
0.5	1.40	50	0	12.0
1.0	1.30	36	0	8.00
1.5	1.20	25	0	4.00
2.0	1.10	12	0	0.00
2.5	1.00	0	12	0.00
3.0	0.90	0	36	10.0
3.5	0.80	0	52	15.0
4.0	0.70	0	66	17.0
4.5	0.60	0	90	24.0
5.0	0.50	0	170	28.0

P5 Spare channel (for user programming)

Gradation	Contrast	Yellow	Magenta	D-Comp
00	1.60	0	0	0.00
0.0	1.50	0	0	0.00
0.5	1.40	0	0	0.00
1.0	1.30	0	0	0.00
1.5	1.20	0	0	0.00
2.0	1.10	0	0	0.00
2.5	1.00	0	0	0.00
3.0	0.90	0	0	0.00
3.5	0.80	0	0	0.00
4.0	0.70	0	0	0.00
4.5	0.60	0	0	0.00
5.0	0.50	0	0	0.00

See section 8 'Checking or setting up a grade table' for information on data entry for this channel.

Table for recording user data

Gradation	Contrast	Yellow	Magenta	D-Comp
00				
0.0				
0.5				
1.0				
1.5				
2.0				
2.5				
3.0				
3.5				
4.0				
4.5				
5.0				

ILFORD

DECLARATION OF CONFORMITY

ILFORD IMAGING UK LIMITED · MOBBERLEY · KNUTSFORD · CHESHIRE WA16 7JL



ILFORD DECLARE UNDER OUR SOLE RESPONSIBILITY THAT PRODUCT

MULTIGRADE600 printing system

NAME · TYPE OR MODEL

TO WHICH THIS DECLARATION RELATES
IS IN CONFORMITY WITH THE FOLLOWING SPECIFICATIONS

SPECIFICATION	NUMBER	EC DIRECTIVE
Electromagnetic compatibility - emissions	EN55022	89/336/EEC
Electromagnetic compatibility - immunity	EN50082-1	89/336/EEC
	EN55024-2	89/336/EEC
	EN55024-3	89/336/EEC
	EN55024-4	89/336/EEC
Low voltage	EN60950	73/23/EEC

NAME OF AUTHORISED OFFICER
Mr M.G.Hammond

POSITION OF AUTHORISED OFFICER
Manager - Central Equipment Group

SIGNATURE OF AUTHORISED OFFICER

DATE

1st October 1998

Australia

ILFORD Imaging Asia Pacific Pty Limited
Monash Corporate Centre
Unit 1, 10 Duerdin Street
Clayton North 3168 Victoria

Benelux

ILFORD Imaging Benelux
Fotografielaan, 18
2610 WILRIJK
ANTWERP
Belgium

Canada

ILFORD Imaging Canada Limited
361 Steelcase Road West
Unit No.4
Markham
Ontario L3R 3V8

France

ILFORD Imaging France SA
14 rue Galilée Cité Descartes
77420 Champs-sur-Marne

Germany/Austria

ILFORD Imaging GmbH
Heinrich-Hertz-Str 1
POB 10 11 68
D-63265 Dreieich

Italy

ILFORD Imaging Italia SpA
Corso Italia 13
21047 Saronno (VA)

Switzerland

ILFORD Imaging Switzerland GmbH
Rue de l'Ancienne Papeterie
CH-1723 Marly 1

United Kingdom

ILFORD Imaging UK Limited
Town Lane
Mobberley
Cheshire WA16 7JL

USA

ILFORD Imaging USA Inc
West 70 Century Road
Paramus
New Jersey 07653

If your country is not shown here, please contact:

Export EAMER Group
ILFORD Imaging UK Limited
Mobberley
Cheshire WA16 7JL
England

Web

www.ilford.com

Constant improvements in ILFORD products mean that changes in design or specification may occur from time to time. Any improvements will, however, maintain conformance of the product with all relevant legislation. The right to alter the design and specification of the equipment without prior notice is accordingly reserved.

Product names printed in capitals are ILFORD trade marks.
ILFORD Imaging UK Limited
Mobberley Cheshire